

Constant Current Control for DC-DC Converters



Contents	Page
Introduction	1
Theory of Operation	1
Power Limitations	2
Voltage Loop Stability	2
Current Control Example	7
Component Values	8
Calculating R_2	11
Calculating R_3 and R_4	11
Calculating R_7	12
Calculating R_8	12
Calculating R_{11} and C_2	13
VI-200 / VI-J00 Converters	13

Introduction

Vicor’s VI-200/VI-J00 and Maxi, Mini and Micro family DC-DC converters are voltage regulating devices, but their wide trim range makes it possible to use them as efficient high-power current sources. Current regulation can be implemented through the addition of an external control loop and current-sense resistor. Such a design must take into account the power limitations of the DC-DC converter and must ensure the stability of the converter’s voltage loop. In addition to these considerations, this application note covers compensation of the external current-control loop and a design example for a simple battery charger.

Theory of Operation

Figure 1 shows a current control configuration for applications requiring basic constant current control. The error amplifier compares the reference voltage to the voltage across the shunt resistor and pulls down the converter SC pin until they are equal. The error amplifier is compensated to stabilize this feedback loop.

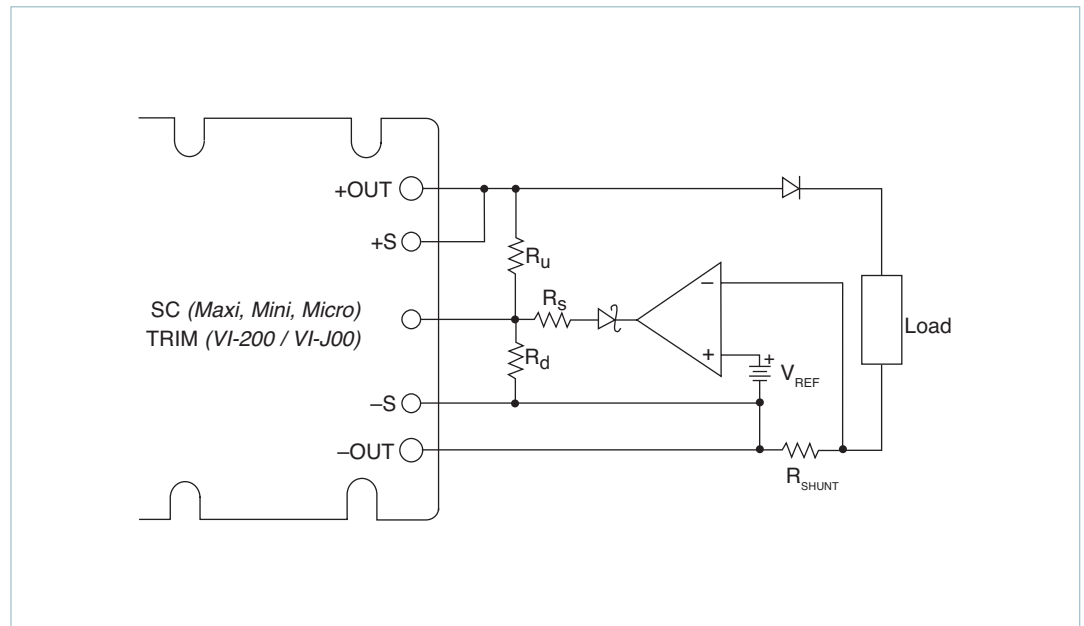

Figure 1
Current Control Block Diagram

The pull up / down network (R_u , R_d and R_s) allows the error amplifier to vary the output of the converter by trimming the SC/TRIM pin while keeping the pin from being driven too high or too low.

The diode in series with the positive lead isolates the output of the converter in the event of a failure. It is required when the load can store significant energy, e.g., with a battery or capacitor.

Circuit V_{cc} can be provided externally or generated directly from the module output using a regulator. The latter option may require that the minimum voltage at the output for the converter be increased.

Power Limitations

Maxi, Mini and Micro modules can be trimmed from 10% to 110% of their nominal output voltages. The trim range for the VI-200 / VI-J00 family is 50% to 110% for most modules. These trim restrictions bound the load impedances for which the module can maintain constant current.

Figure 2 shows the Safe Operation Area (SOA) of a Maxi, Mini or Micro converter. A properly designed current source will operate on a horizontal line inside this area.

Figure 2
Maxi, Mini and Micro
Safe Operating Area

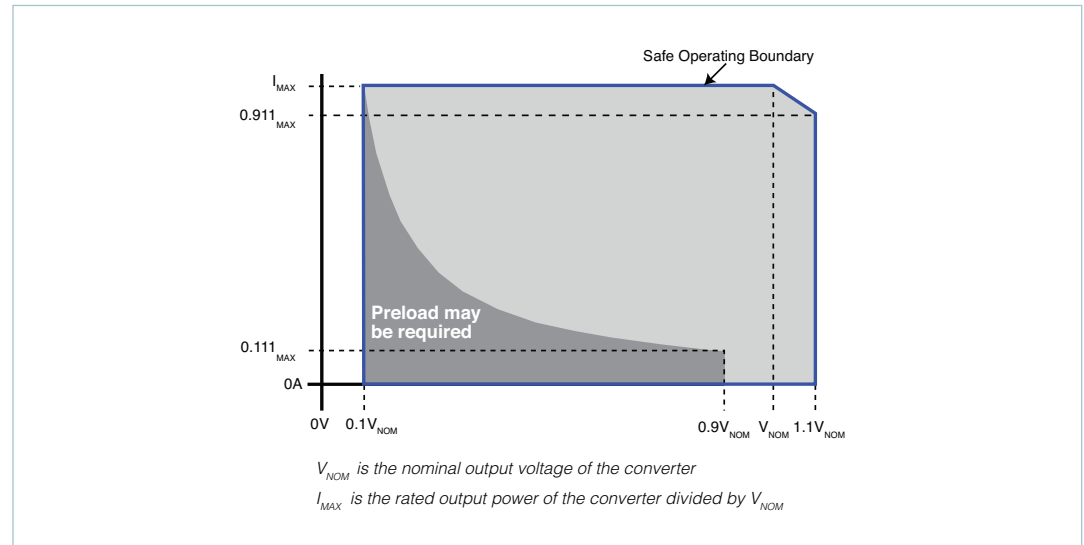

From 10% to 100% V_{NOM} maximum output power is determined by the maximum current rating of the converter (I_{MAX}). This current rating is fixed and does not increase as the output voltage of the converter decreases. For output voltages above V_{NOM} the output current must be reduced to comply with the maximum power rating of the converter. Modules must not be trimmed above 110% V_{NOM} as this can damage the converter.

Vicor converters have an internal current limit designed to reduce the risk of damage to the module during a fault condition. This limit should not be used as part of normal operation because the converter may be driven into an overpower condition or unstable operation. Trimming down a converter cannot fully protect against overcurrent because there is a limit to the percentage by which the output voltage can be reduced. This requires that an external circuit be implemented for loads that do not have lower bounds on their impedance.

Similarly, the converter output overvoltage protection function is meant to protect it in the event of a failure and should not be intentionally activated. VI-J00 converters do not have OVP.

Voltage Loop Stability

No DC-DC converter will be inherently stable for every load, and compensation must be optimized using assumptions about the load. This is important for the current-source designer because typical loads for a current source such as large capacitors may place excessive demands on the internal compensation of the converter voltage loop.

Large capacitors with low ESR at the output of a converter can modify the voltage loop enough to degrade phase margin and even cause oscillation. For the converter internal voltage loop to remain stable, the load impedance must have a minimum real component; see Figure 3. Contributions to this real component include lead/trace resistance, capacitor or battery ESR, diode forward resistance and any current-sense resistor.

The best way to find the minimum value for this resistive term is the use of a network analyzer to verify ample phase margin with the load and series resistance in place. For Maxi, Mini and Micro converters use 5% of the minimum load resistance (Minimum Series Resistance = $R_{FULL-LOAD} \times 0.05$) as a starting value for minimum series resistance for the module.

Figure 3
Placement of Real Impedance

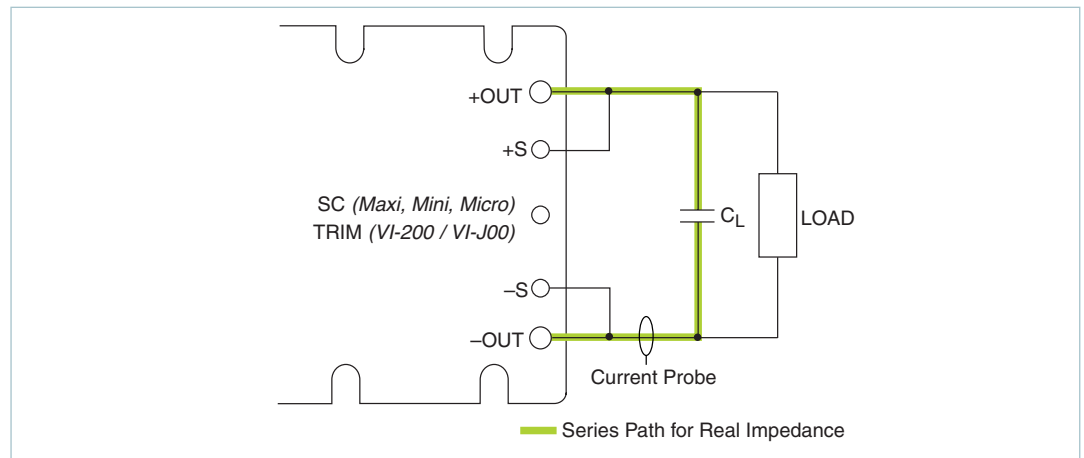

For example, a 250W converter with 28V output will be at full load with 3.1Ω at the output. Thus, a good first choice of cumulative series resistance is:

$$\frac{(28V)^2}{250W} \cdot 0.05 = 157m\Omega$$

Many factors affect stability including load, line and circuit parasitics. This makes application-specific testing essential.

If a network analyzer is not available or it is impossible to break the voltage loop, a step response can be used to assess stability. With large capacitors in place, voltage perturbations on the output will be hard to detect. A better method is to use a current probe to look at the current at the output of the module; see Figure 3. Excessive low frequency ringing or oscillations in the module output current after a load current step indicates poor stability. Contact Vicor Applications Engineering with further questions on driving capacitive loads.

Trimming down a module under light load can also degrade stability. If a module is trimmed below 90% of its nominal output voltage a preload may be required to ensure stability as shown in Figure 2 (SOA curve). For information on active preloads see the Vicor application note:

[“Wide Range Trimming with Variable Loads”](#).

Current Loop Compensation

Once the voltage loop of the converter displays good stability, a current control loop can be designed. Compensating the current loop involves decreasing the overall loop gain such that phase shift has not become excessive at the unity gain point.

An important consideration when choosing current-loop compensation is the limitations of the DC-DC converter’s voltage control loop. To illustrate this, Bode plots for Maxi and Mini modules can be taken by breaking the feedback loop between +OUT and +S and injecting a stimulus: Figure 4. The voltage-loop response can then be measured as the ratio of the test phasor at +OUT to the reference phasor at the +S pin.

Figure 4
Bode Plot Measurement Setup

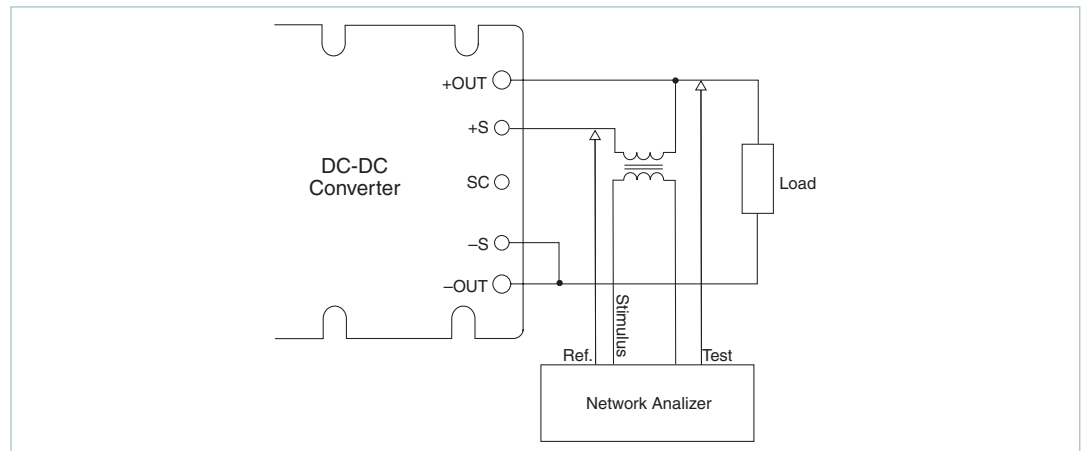

Most Maxi, Mini and Micro converters have a zero dB crossover point between 3 to 30kHz that varies with line and load. For example, bode plots for a V48B12C250B are shown in Figures 5 and 6 for 100% load and 10% load respectively.

Figure 5

V48B12C250B Bode Plot
100% load, $I_L = 20.8A$, $V_{IN} = 48V$

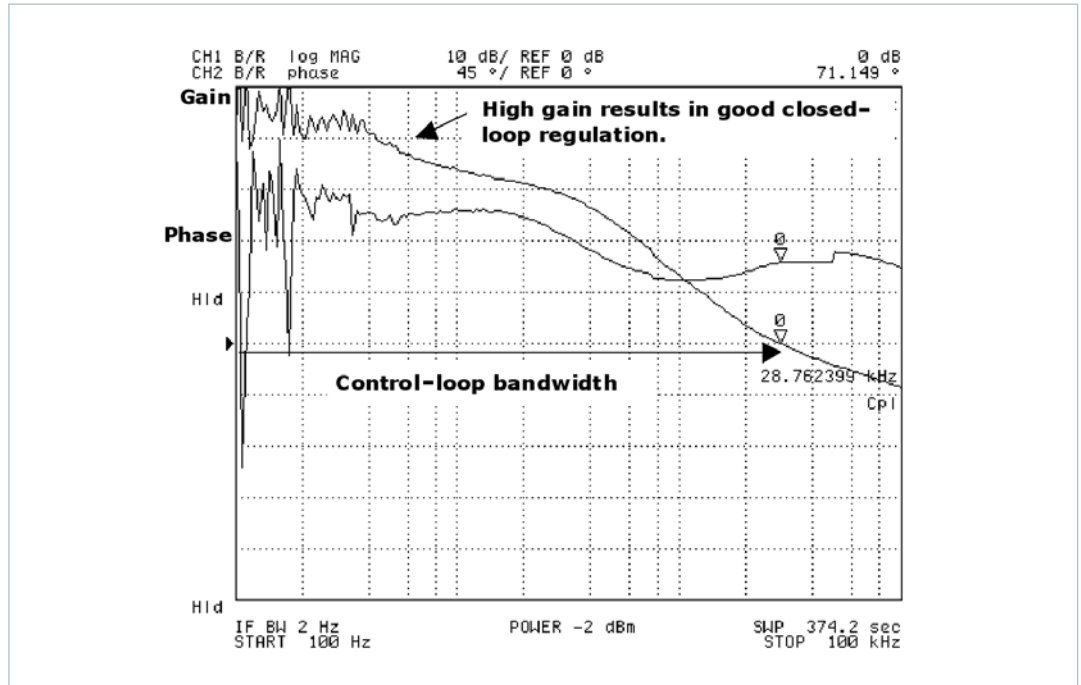
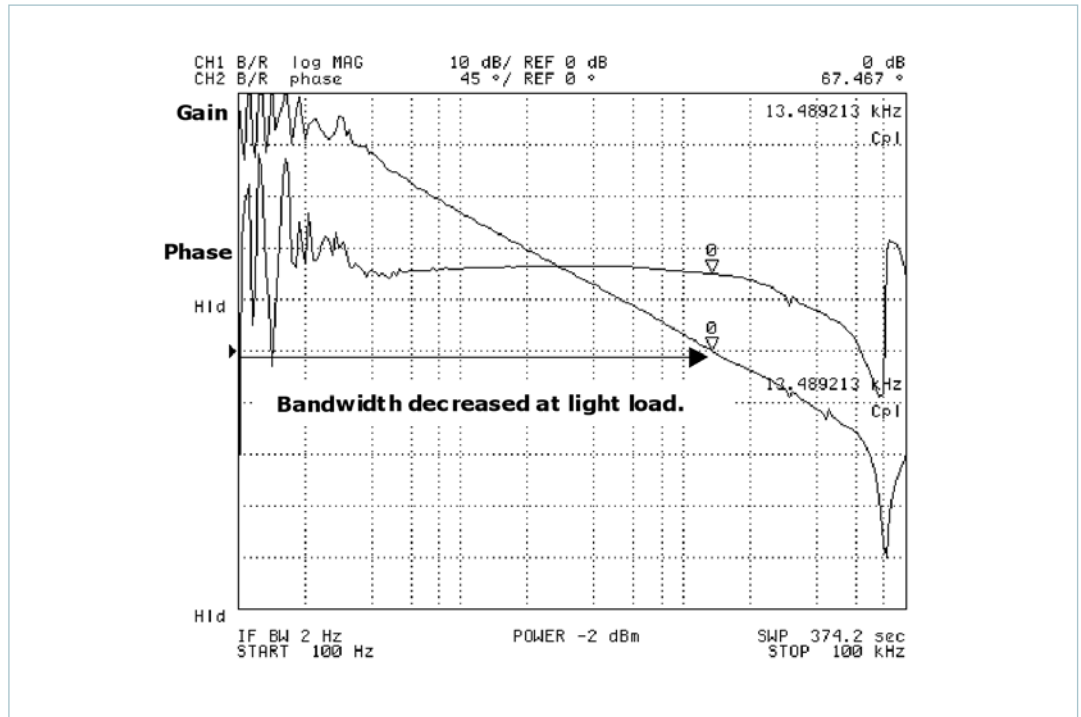

Figure 6

V48B12C250B Bode Plot
10% load, $I_L = 2.1A$, $V_{IN} = 48V$



Control loops that contain an internal loop should have a bandwidth well below the internal loop crossover frequency so that the two loops do not interact. Figure 8 shows a response from the same converters SC pin to the output voltage taken using the setup in Figure 7.

Figure 7
Trim Response
Measurement Setup

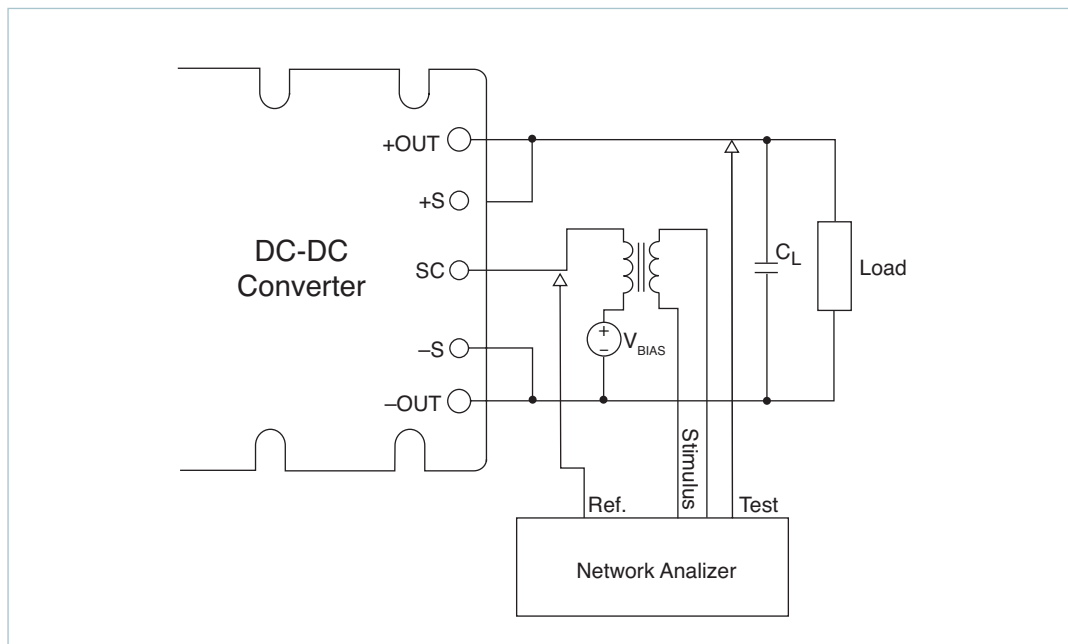

At frequencies inside the converter bandwidth the gain is equal to $V_{NOM} / 1.23V$ while outside the bandwidth the response quickly deteriorates. An external current loop that uses the SC pin should operate well within this constant gain region.

Figure 8
 $V48B12C250B$ SC to V_{OUT} ,
 $I_L = 1.8A$, $C_L = 0$, $V_{IN} = 48V$

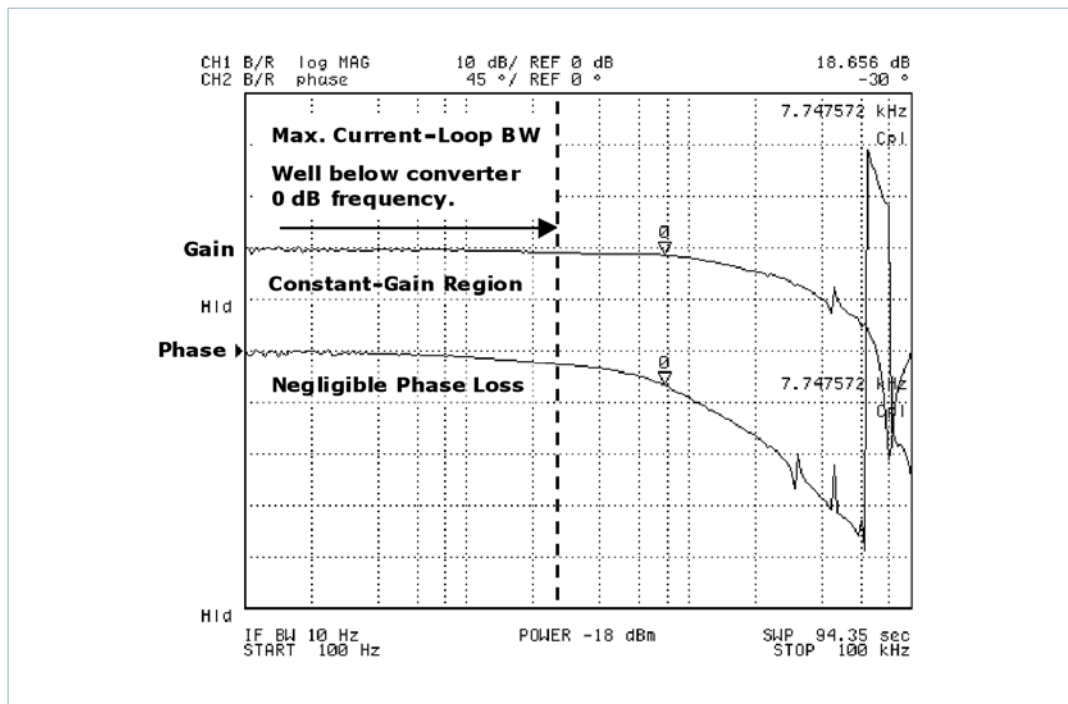

Load impedance will affect the converter crossover frequency. Figure 9 shows the same plot but with a large capacitor at the output of the converter causing the region of flat gain and low phase displacement to drop to a much lower frequency.

The loop response will also be affected by the filter formed by the load impedance and the current-sense resistor. This will cause gain and phase change to the loop that will depend on the application.

Figure 9
 V48B12C250B SC to V_{OUT} ,
 $I_L = 1.8A$, $C_L = 10,000\mu F$,
 $V_{IN} = 48V$

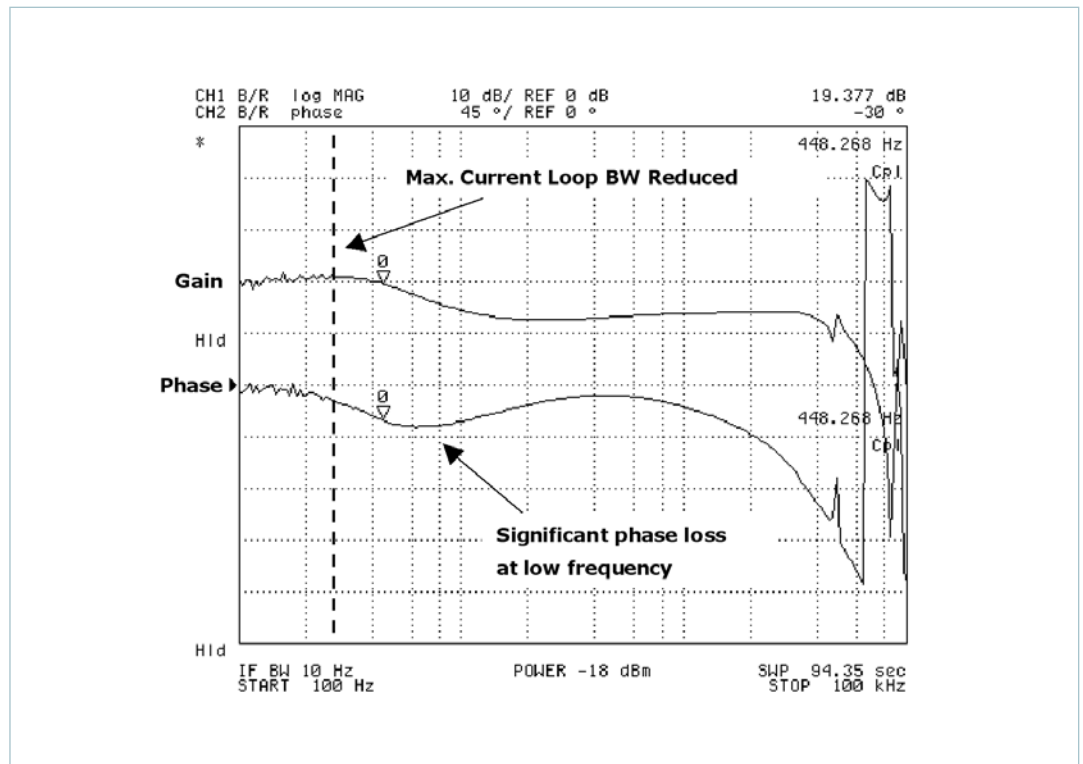
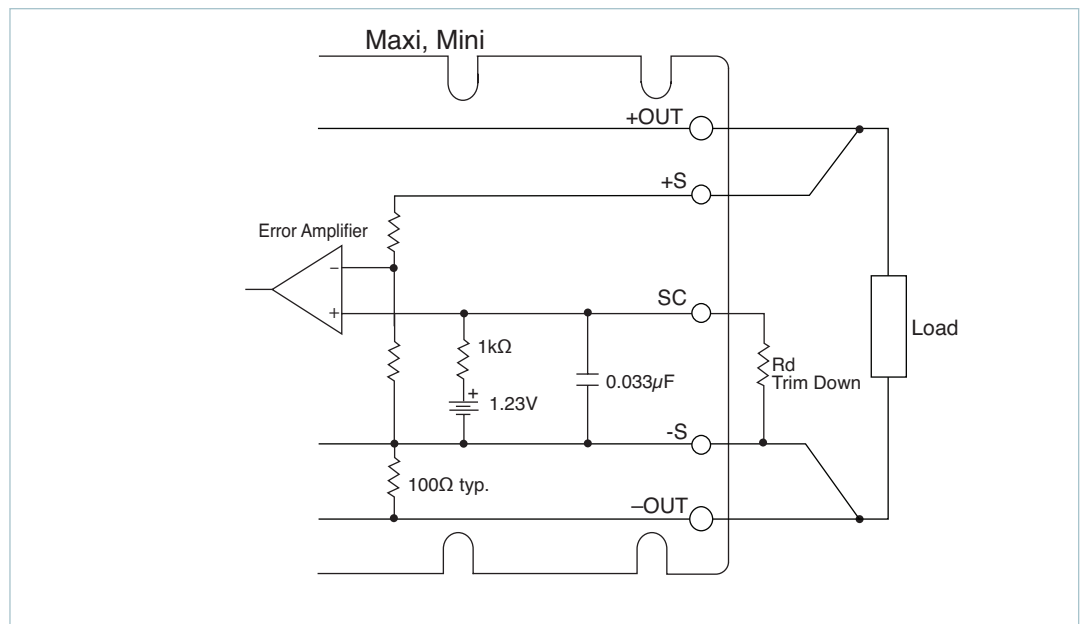

Figure 10
 Internal Connection of SC Pin of
 Maxi and Mini Converters



NOTE: An additional restriction on loop bandwidth results because the output of the converter can only source current, so any decrease in voltage is limited by the RC time constant of the load resistance and capacitance. This will result in nonlinearities for signals that change more rapidly than this RC discharge time. This is especially important at light loads.

Practically, this type of current controller is limited to relatively low bandwidth applications due to phase shift caused by the DC-DC converter control loop, RC discharge nonlinearity, load impedance, and capacitance internal to the SC pin in Figure 10.

For these low-bandwidth applications a single-pole compensation scheme is adequate. This should be configured such that it has a crossover below the frequency where significant phase shift enters the loop. It can then be optimized using network analyzer or load step responses. For designs with complex loads and strict transient requirements, more complicated compensation may be required.

Current Control Example

The following example covers the component selection for a simple lead-acid battery charger using a DC-DC converter brick. The schematic for this charger is shown in Figure 11.

Figure 11
Battery Charger Schematic

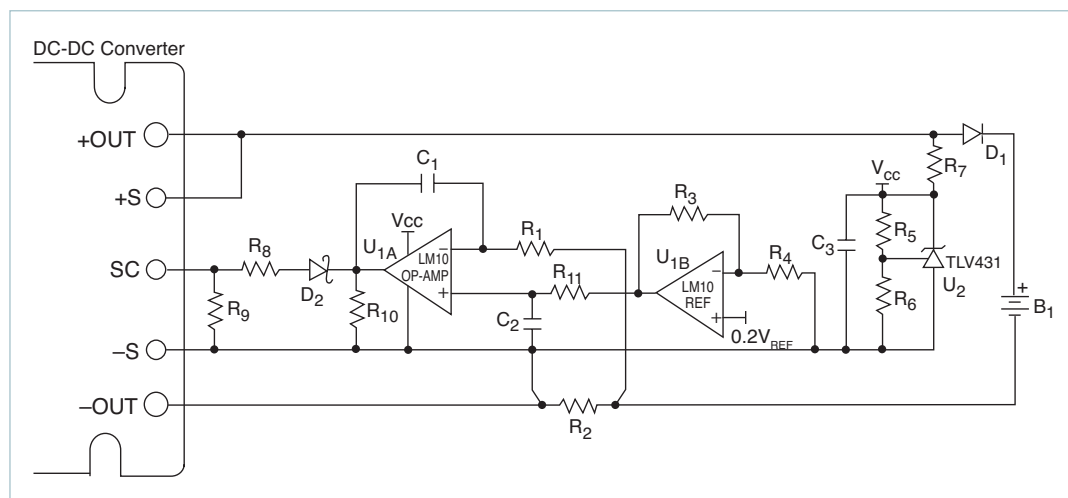

NOTE: A redundant control or monitoring circuit must be included if failure of the charger or its control circuit will result in uncontrolled charging of the battery. Many new battery types are sensitive to these conditions and may result in fire or explosion.

The heart of this circuit is an LM10 (U_1) that provides an operational amplifier (op-amp), 0.2V reference and reference buffer in a single package. The op-amp (U_{1A}) functions as the error amplifier and is configured as an integrator using C_1 and R_1 . The internal reference voltage is scaled up by R_3 and R_4 to establish the desired voltage at the non-inverting op-amp input. If a reference lower than 0.2V is required, R_3 and R_4 can be replaced by a resistive divider at the output of the reference buffer (U_{1B}).

To control load current, the reference voltage is compared with the Kelvin-sensed voltage across the current-sense resistor R . U_{1A} drives the cathode of Schottky diode D_2 to trim the module output until the two signals are equal. R_{10} allows C_1 to completely discharge when voltage is removed from the circuit to establish initial conditions.

Table 1
BOM for 12V, 5A
Charger Using V48B15C250B

Ref. Des.	Value	Rating
R ₁	2.32k Ω	0.25W
R ₂	0.05 Ω	2.0W
R ₃	20k Ω	0.25W
R ₄	80.6k Ω	0.25W
R ₅	1k Ω	0.25W
R ₆	1.62k Ω	0.25W
R ₇	787 Ω	0.5W
R ₈	453 Ω	0.25W
R ₉	12.7k Ω	0.25W
R ₁₀	49.9k Ω	0.25W
R ₁₁	14.7k Ω	0.25W
C ₁	0.47 μ F	16V
C ₂	0.68 μ F	16V
C ₃	470 μ F	100V
D ₁	Vishay MBR1045 Schottky Rectifier	10A, 45V
D ₂	NXP 1PS76SB10 Schottky Diode	200mA, 30V
U ₁	National LM10 Op Amp and Reference	—
U ₂	TI TLV431 Shunt Regulator	—
—	Vicor V48B15C250B DC-DC Converter	15V, 250W

D_2 prevents the op-amp from overdriving the SC pin, while its low forward voltage improves the output-voltage range of the source. For Maxi, Mini and Micro converters this diode should be chosen so that its reverse leakage is less than roughly $125\mu\text{A}$ over temperature, or a 10% trim up of the module. Reverse leakage should be less than $25\mu\text{A}$ for VI-200 / VI-J00 converters.

As the battery state of charge increases, the battery voltage levels off to a constant float voltage. R_9 reduces the maximum output voltage of the converter thereby setting the float voltage. R_8 and the forward voltage of D_2 set the minimum current source voltage. This determines the minimum load impedance the source can safely drive.

For loop compensation to be effective, the circuit must be referenced directly at the converter –S pin to avoid ground bounce from feeding into the SC pin and degrading loop stability. For Micro modules, which do not have remote sense pins, it is mandatory that the shunt be placed directly at the –OUT pin. Placing the shunt close to the –OUT lead is good practice for all converters, and it is especially important when driving loads such as large capacitors that place higher demand on a converter’s remote sensing capability.

The op-amp and reference are supplied from the output of the converter via a shunt regulator (U_2) that is programmed to provide a 2V rail.

Diode D_1 is included for fault protection and to prevent the battery from driving the circuit when the charger is off.

Component Values

The following example illustrates how to configure this circuit for the required charge rate and float voltage. Consider a 12V, 50A hour battery that will be charged at a C/10 rate or 5A. The selected float voltage is 13.4V. The circuit will be implemented using the V48B15C250B Mini module.

Calculating R_1

Because transient response is not critical in charger applications, R_1 should be chosen such that the integrator crossover frequency is well below the point where the feedback loop sees significant phase shift. Setting this frequency at 200Hz is a good starting value.

For this example, contributions to loop gain are approximated as follows:

$$G_{LOOP} = G_{SC} + G_{PULLDOWN} + G_{LOAD} + G_{COMP}$$

Where G_{SC} is the gain from the SC pin to the converter output and is given by:

$$G_{SC} = 20 \log \left(\frac{V_{NOM}}{V_{REF}} \right) = 20 \log \left(\frac{15V}{1.23V} \right) = 21.72dB$$

Where V_{REF} is the reference voltage internal to the converter’s SC pin; see Figure 10.

Gain from the op-amp output to the SC pin is $G_{PULLDOWN}$ and is given by:

$$G_{PULLDOWN} = 20 \log \left(\frac{R_9 \parallel R_{SC}}{R_8 + R_9 \parallel R_{SC}} \right) = 20 \log \left(\frac{12.7k\Omega \parallel 1k\Omega}{453\Omega + 12.7k\Omega \parallel 1k\Omega} \right) = -3.45dB$$

Where R_{SC} is the source resistance of the converter’s SC pin; see Figure 10.

G_{LOAD} is the attenuation of the load/shunt filter and is given by:

$$G_{LOAD} = 20 \log \left(\frac{R_2}{Z_{LOAD} + R_2} \right) = 20 \log \left(\frac{0.05\Omega}{0.30\Omega} \right) = -15.56dB$$

where the battery small signal impedance is estimated as 0.25Ω based on a current voltage curve.

This assumes the battery impedance is predominantly resistive at these low frequencies.

Compensation gain, G_{COMP} , is given by:

$$G_{comp} = 20 \log \left(\frac{I}{2\pi f R_1 C_1} \right)$$

To attain the required crossover frequency, system gain must be equal to unity at the selected frequency. This can be achieved by first setting G_{loop} equal to 0dB in the equation for loop gain and then solving for the compensation:

$$G_{COMP} = -(G_{SC} + G_{PULLDOWN} + G_{LOAD})$$

$$20 \log \left(\frac{I}{2\pi f R_1 C_1} \right) = -(21.72dB - 3.45dB - 15.56dB)$$

$$\frac{I}{2\pi f R_1 C_1} = 0.732$$

so choosing C_1 as $0.47\mu F$ yields

$$R_1 = \frac{I}{2\pi f C_1 (0.732)} = \frac{I}{2\pi (200Hz)(0.47\mu F)(0.732)} = 2.31k\Omega$$

The closest 1% standard value is $2.32k\Omega$.

A loop response for a charger with this configuration is shown in Figure 12 and displays good phase margin well above 45°. The 15% error from the calculated crossover frequency is within the tolerance of the integrator capacitor. Time domain analysis also reveals a very stable system as shown in the well-damped step response of Figure 13.

Figure 12
 12V Battery Charger Loop
 Response with V48B15C250B,
 $I_{charge} = 5A$

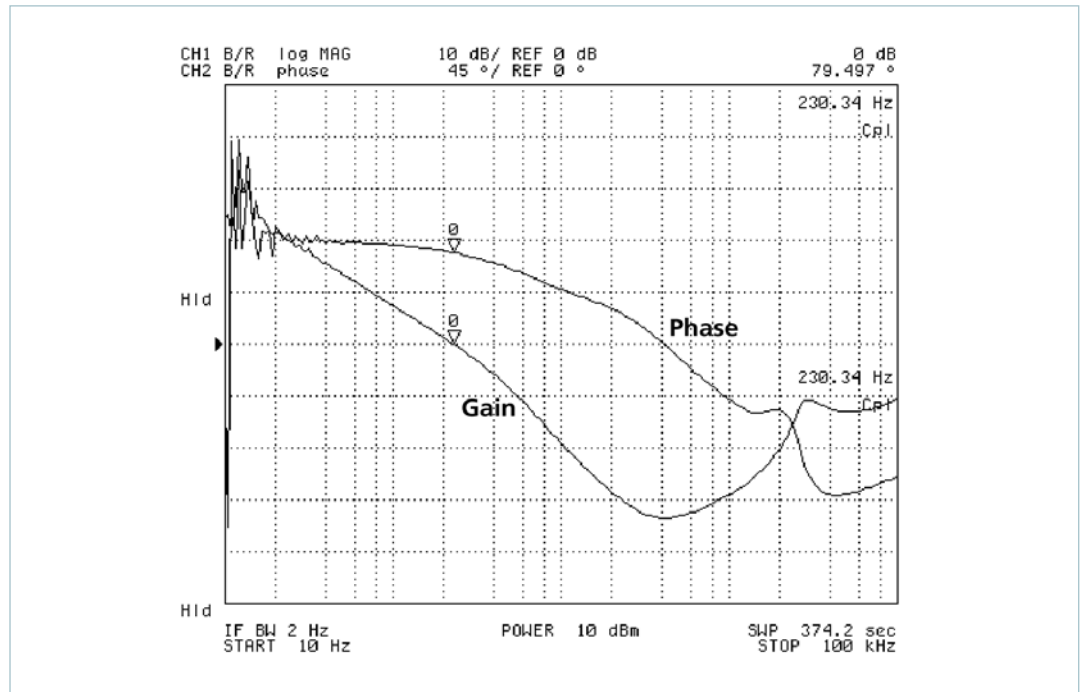
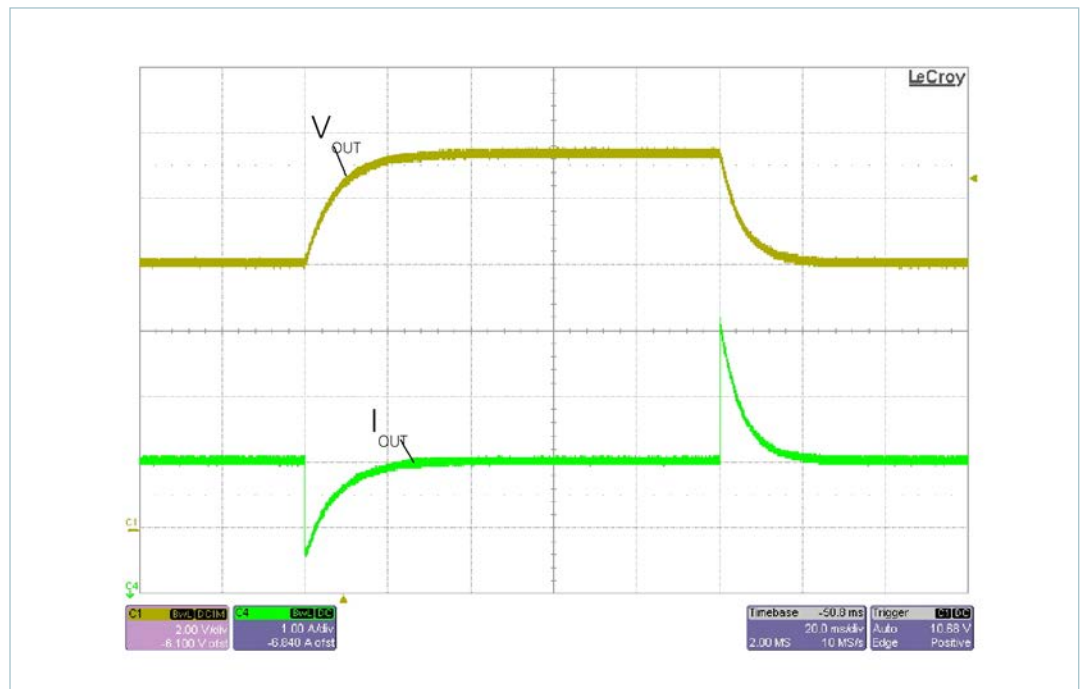

Figure 13
 Battery Charger Step
 Response with V48B15C250B,
 1.5Ω to 2.2Ω steps



Calculating R₂

Because batteries can act as large capacitors, it is necessary to choose a shunt that will stabilize the module voltage loop. For this converter the suggested starting series resistance is:

$$\frac{V_{NOM}^2}{P_{OUT}} \cdot 0.05 = \frac{(15V)^2}{250W} \cdot 0.05 = 45m\Omega$$

Once this shunt is large enough to stabilize the voltage loop, the selection of the sense resistor involves a tradeoff between current set point accuracy and power dissipation. For the configuration in Figure 7, accuracy will depend on the ratio of the op-amp offset voltage (2mV maximum for the LM10) to the voltage across the shunt. If high accuracy and low dissipation are required, a low offset op-amp can be used to preamplify the low-level signal from the shunt.

For example, choosing a 50mΩ shunt and configuring the circuit for a 5A charge current will put 250mV across the shunt. If R₃ and R₄ are 1% resistors the reference will be accurate to about 6% for an overall accuracy of:

$$0.06 + \frac{V_{OS}}{V_{SHUNT}} = 0.06 + \frac{2mV}{250mV} = 6.8\%$$

Thus, offset errors are not significant with R₂ = 50mΩ. Power dissipation for this resistor is then given by:

$$P_{R2} = R_2(I_{CHARGE})^2 = (50m\Omega)(5A)^2 = 1.25W$$

Calculating R₃ and R₄

The selection R₃ and R₄ is based on attaining the proper reference voltage at the non-inverting input of U_{1A}. By setting R₃ as 20kΩ R₄ can be calculated as:

$$R_4 = R_3 \left(\frac{V_{REF, LM10}}{V_{REF} - V_{REF, LM10}} \right) = 20k\Omega \left(\frac{0.2V}{0.25V - 0.2V} \right) = 80k\Omega$$

where:

V_{REF} is voltage at U_{1A} non-inverting input

(V_{REF} = R₂I_{CHARGE} = 50mΩ x 5A = 0.25V)

V_{REF, LM10} is internal reference voltage of LM10 (200mV typ.)

The closest 1% standard value is 80.6kΩ.

Calculating R₇

R₇ should be chosen such that current fed into the TLV431 regulator (U₂) is approximately 15mA. The following equations can be used to find the appropriate value for R₇ and its power dissipation P_{R7}:

$$R_7 = \frac{V_{MAX} - 2V}{15mA} = \frac{13.9V - 2V}{15mA} = 793\Omega$$

The closest 1% standard value is 787Ω.

$$P_{R7} = (V_{MAX} - 2V) 15mA = (13.9V - 2V) 15mA = 0.179W$$

Where V_{MAX}, the required maximum output voltage, is given as V_{MAX} = V_{FLOAT} + 0.5V = 13.9V to take into account the 0.5V drop on the Schottky protection rectifier D₁.

Calculating R₈

R₈ in conjunction with the forward voltage of D₂ gives the minimum output voltage of the converter. To provide ample trim down capability this is set as 6.95V or half the maximum output voltage.

$$R_8 = \frac{R_{SC} R_9 (V_{MIN} V_{REF, SC} - V_{f, D2} V_{NOM})}{V_{REF, SC} (V_{NOM} - V_{MIN}) R_9 - V_{MIN} V_{REF, SC} R_{SC}}$$
$$= \frac{1k\Omega \cdot 12.63k\Omega (6.95V \cdot 1.25V - 0.29V \cdot 15V)}{1.23V (15V - 6.95V) 12.63k\Omega - 6.95V \cdot 1.23V \cdot 1k\Omega} = 455\Omega$$

where:

V_{REF, SC} is the 1.23V reference internal to Vicor's Maxi, Mini and Micro converters

V_{NOM} is the converter nominal output voltage

R_{SC} is an internal pull up resistor on the SC pin of Vicor's Maxi, Mini and Micro converters, see Figure 10

V_{MIN} is the required minimum output voltage

V_{f, D2} is the forward voltage of D₂ at approximately 1mA

The closest 1% standard value is 453Ω.

Calculating R₉

R₉ trims down the module to set the maximum converter output voltage. It can thus be used to set the battery float voltage. This gives:

$$R_9 = R_{SC} \left(\frac{V_{MAX}}{V_{NOM} - V_{MAX}} \right) = 1k\Omega \left(\frac{13.9V}{15V - 13.9V} \right) = 12.63k\Omega$$

where:

V_{MAX} is the maximum output voltage of the converter (V_{float} + V_{f, D1})

V_{NOM} is the nominal output voltage of the converter

R_{SC} is an internal pull up resistor on the SC pin of Vicor's Maxi, Mini and Micro converters

The closest 1% standard value is 12.7kΩ.

Calculating R₁₁ and C₂

The time constant created by R₁₁ and C₂ controls the start-up behavior of the circuit to reduce overshoot. It should be chosen such that the reference is still low after the 4ms converter soft start ramp is complete. This suggests a RC product of 10ms. Letting C₂ = 0.68μF gives:

$$R_{11} = \frac{10\text{ms}}{0.68\mu\text{F}} = 14.7\text{k}\Omega$$

Charger start-up with the above values is shown in Figure 14. The load consists of a partially discharged 12V lead acid battery.

Figure 14
Battery Charger Startup
with V48B15C250B, I_{charge} = 5A

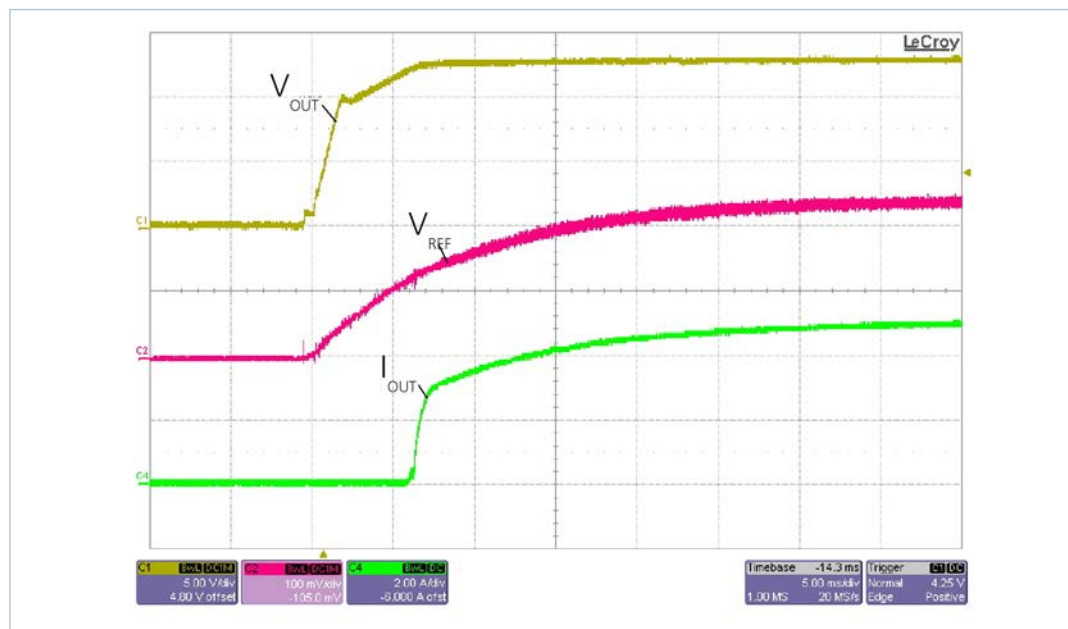

VI-200 / VI-J00 Converters

Designing a battery charger around VI-200/VI-J00 family converters follows a similar process as for the Maxi, Mini and Micro family. The example below demonstrates a 24V battery charger with 2.5A charge current and 26.9V float voltage to be configured using a VI-JWL-MX converter. The BOM is given in Table 2 and corresponds to the schematic shown in Figure 11.

From the standpoint of current control, the most important differences between VI-200/VI-J00 converters and the Maxi, Mini and Micro family are in the internal circuitry of the TRIM pin, Figure 15. This leads to changes in the value of the reference voltage and pull-up resistor in the equations for resistors R₈ and R₉. In addition, the value of R₈ must take into account the 50% trim down capability of most VI-200/VI-J00 modules, so minimum output voltage (V_{MIN}) is increased to from 50% to 75% of V_{MAX}.

Table 2
BOM for 24V Charger
Using VI-JWL-MX

Ref. Des.	Value	Rating
R ₁	26.1kΩ	0.25W
R ₂	0.6Ω	4.0W
R ₃	20kΩ	0.25W
R ₄	3.09kΩ	0.25W
R ₅	1kΩ	0.25W
R ₆	698Ω	0.25W
R ₇	1.65kΩ	0.5W
R ₈	24.3kΩ	0.25W
R ₉	240kΩ	0.25W
R ₁₀	49.9kΩ	0.25W
R ₁₁	73.2kΩ	0.25W
C ₁	0.47μF	16V
C ₂	0.68uF	16V
C ₃	470pF	100V
D ₁	Vishay MBR1045 Schottky Rectifier	10A, 45V
D ₂	NXP 1PS765B10 Schottky Diode	200 mA, 30V
U ₁	National LM10 Op Amp and Reference	—
U ₂	TI TLV431 Shunt Regulator	—
—	Vicor VI-JWL-MX DC-DC Converter	28V, 75W

Figure 15
Internal Connection of TRIM Pin
of VI-200/VI-J00 Converters

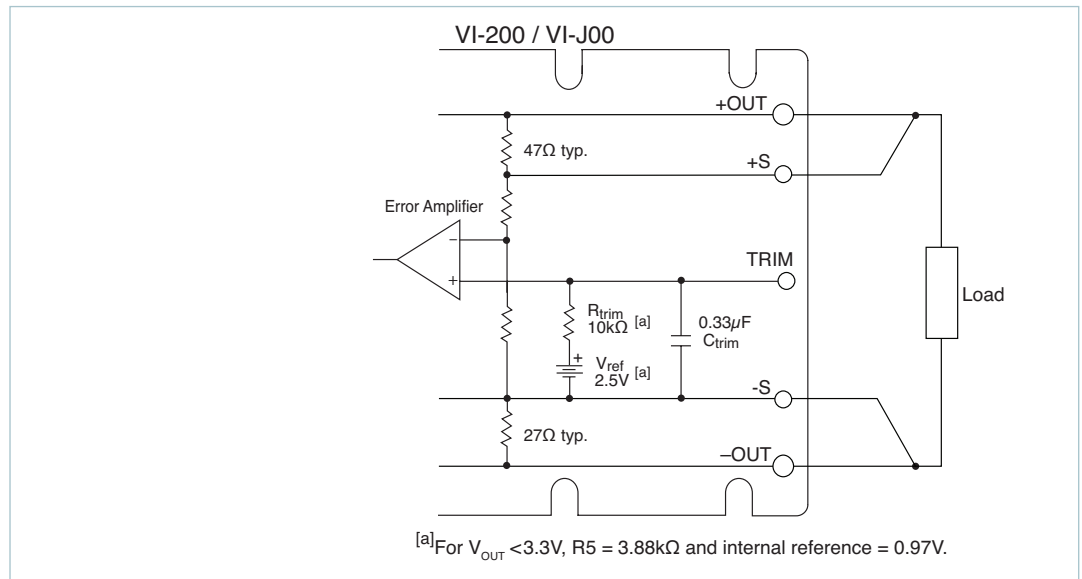

Selection of compensation resistor (R_1) is modified because of a low-frequency pole introduced into the frequency response by C_{TRIM} and R_{TRIM} , Figure 15. This pole is at 47Hz two decades lower in frequency than in Maxi, Mini and Micro converters. The low-frequency phase shift caused by the pole requires that a more conservative crossover frequency be used. For this example, 50Hz is selected which causes R_1 to be increased following the procedure for the Maxi, Mini and Micro family battery charger.

The startup of VI-200/VI-J00 converters is less tightly controlled than in Maxi, Mini and Micro converters. The time constant of the reference ramp (R_{11} , C_2) has been increased to 50ms to reduce overshoot on start-up. Circuit V_{CC} has been increased to 3V to comply with the LM10's common mode range. This is necessary, given the larger shunt and reference voltage (1.5V).

For more information on current control capabilities, contact: <http://www.vicorpower.com/contact-us>.

Limitation of Warranties

Information in this document is believed to be accurate and reliable. HOWEVER, THIS INFORMATION IS PROVIDED "AS IS" AND WITHOUT ANY WARRANTIES, EXPRESSED OR IMPLIED, AS TO THE ACCURACY OR COMPLETENESS OF SUCH INFORMATION. VICOR SHALL HAVE NO LIABILITY FOR THE CONSEQUENCES OF USE OF SUCH INFORMATION. IN NO EVENT SHALL VICOR BE LIABLE FOR ANY INDIRECT, INCIDENTAL, PUNITIVE, SPECIAL OR CONSEQUENTIAL DAMAGES (INCLUDING, WITHOUT LIMITATION, LOST PROFITS OR SAVINGS, BUSINESS INTERRUPTION, COSTS RELATED TO THE REMOVAL OR REPLACEMENT OF ANY PRODUCTS OR REWORK CHARGES).

Vicor reserves the right to make changes to information published in this document, at any time and without notice. You should verify that this document and information is current. This document supersedes and replaces all prior versions of this publication.

All guidance and content herein are for illustrative purposes only. Vicor makes no representation or warranty that the products and/or services described herein will be suitable for the specified use without further testing or modification. You are responsible for the design and operation of your applications and products using Vicor products, and Vicor accepts no liability for any assistance with applications or customer product design. It is your sole responsibility to determine whether the Vicor product is suitable and fit for your applications and products, and to implement adequate design, testing and operating safeguards for your planned application(s) and use(s).

VICOR PRODUCTS ARE NOT DESIGNED, AUTHORIZED OR WARRANTED FOR USE IN LIFE SUPPORT, LIFE-CRITICAL OR SAFETY-CRITICAL SYSTEMS OR EQUIPMENT. VICOR PRODUCTS ARE NOT CERTIFIED TO MEET ISO 13485 FOR USE IN MEDICAL EQUIPMENT NOR ISO/TS16949 FOR USE IN AUTOMOTIVE APPLICATIONS OR OTHER SIMILAR MEDICAL AND AUTOMOTIVE STANDARDS. VICOR DISCLAIMS ANY AND ALL LIABILITY FOR INCLUSION AND/OR USE OF VICOR PRODUCTS IN SUCH EQUIPMENT OR APPLICATIONS AND THEREFORE SUCH INCLUSION AND/OR USE IS AT YOUR OWN RISK.

Terms of Sale

The purchase and sale of Vicor products is subject to the Vicor Corporation Terms and Conditions of Sale which are available at: (<http://www.vicorpower.com/termsconditionswarranty>)

Export Control

This document as well as the item(s) described herein may be subject to export control regulations. Export may require a prior authorization from U.S. export authorities.

Contact Us: <http://www.vicorpower.com/contact-us>

Vicor Corporation

25 Frontage Road
Andover, MA, USA 01810
Tel: 800-735-6200
Fax: 978-475-6715
www.vicorpower.com

email

Customer Service: custserv@vicorpower.com
Technical Support: apps@vicorpower.com