

Whenever power supplies or converters are operated in a parallel configuration – whether for higher output power, fault tolerance or both – current sharing is an important consideration. Most current-sharing schemes employed with power converters involve either artificially increasing the output impedance of the converter module or actually sensing each output current, forcing all of the currents to be equal by feedback control. In a synchronous current-sharing scheme, however, there is no need for having a current-sensing or current-measuring device on each module, nor is there a need to artificially increase the output impedance, which compromises load regulation.

Why Current Sharing Is Important

Most paralleled power components – transistors, rectifiers, power conversion modules, offline power supplies – will not inherently share the load. In the case of power converters, one or more of the converters will try to assume a disproportionate or excessive fraction of the load unless forced current-share control is designed into the system. One converter – typically the one with the highest output voltage – may deliver current up to its current limit setting, which is beyond its rated maximum. Then the voltage will drop to the point where another converter in the array – the one with the next highest voltage – will begin to deliver current. All of the converters in an array may deliver some current, but the load will be shared unequally. Built-in current limiting may cause all or most converters to deliver current, but the loading will remain unbalanced, and potentially cause damage to the converters.

Consider the situation when one module in a two-module array is providing all of the load. If it fails, the load on the second module must go from no load to full load, during which time the output voltage is likely to droop temporarily. This could result in system problems, including shutdown or reset. If both modules were sharing the load and one failed, however, the surviving module would experience a much less severe transient (one half to full load), and the output voltage would be likely to experience no more than a slight momentary droop. The dynamic response characteristic of all forward converters, resonant or pulse-width modulated, is degraded when the load is stepped from zero (no load) where the output inductor current is discontinuous.

In the same two-module array example, the module carrying all of the load is also generating all of the heat, resulting in a much lower mean time between failure (MTBF) for that module. An often-quoted rule of thumb says that for each 10°C increase in operating temperature, average component life is cut in half. In a current-sharing system, all of the converters or supplies run at a lower temperature than some modules would in a system without current sharing. As a result, all of the modules age equally.

Current sharing, then, is important because it improves system performance; it minimizes transient / dynamic response and thermal problems and improves reliability. It is an essential ingredient in most systems that use multiple power supplies or converters for higher output power or for fault tolerance.

Current Sharing in Power Expansion Arrays

When parallel supplies or converters are used to increase power, current sharing is achieved by a number of approaches. One scheme simply adds resistance in series with the load. A more practical variant of that is the “droop-share” method, which actively causes the output voltage to drop in response to increasing load. The two most commonly used approaches to paralleling converters for power expansion are the driver / booster or master / slave arrays and analog current-share control. They appear to be similar, but the implementation of each is quite different. Driver / booster arrays usually contain one intelligent module or driver, and one or more powertrain-only modules or boosters. Analog current-share control involves paralleling two or more identical modules, each containing intelligence.

Droop Share: The droop-share method, shown in Figure 5.1, increases the output impedance to force the currents to be equal. It is accomplished by an error signal, which is interjected into the control loop of the converter causing the output voltage to operate as a function of load current. As load current increases, output voltage decreases. All of the modules will have approximately the same amount of current because they are all being summed into one node. If one supply is delivering more current than another supply, its output voltage will be forced down a little so that it will be delivering equal current for an equal voltage out of that summing node. Figure 5.1 illustrates a simple implementation of this scheme where the voltage dropped across the ORing diode, being proportional to current, is used to adjust the output voltage of the associated converter.

Droop share has advantages and disadvantages. One of the advantages is that it can work with any topology. It is also fairly simple and inexpensive to implement. A major drawback, though, is that it requires that the current be sensed. A current-sensing device is needed in each of the converters or power supplies. In addition, a small penalty is paid in load regulation, although in many applications this is not an issue.

In general, it is not recommended to mix and match converters, especially those with incompatible current-sharing schemes. The droop-share method, however, is more forgiving in this regard than with any of the other methods. Current sharing can be achieved using arrays constructed from different converter models or even from different suppliers with a little external circuitry.

Driver / Booster Arrays: Most Vicor converters can employ the driver / booster array for increased power. (Figure 5.2) Driver / booster arrays usually contain one intelligent module or driver, and one or more powertrain-only modules or boosters. The driver is used to set and control output voltage, while booster modules are used to increase output power to meet system requirements.

Driver / booster arrays of quasi-resonant converters with identical powertrains inherently current share because the per-pulse energy of each converter is the same. If the inputs and outputs are tied together and the units have the same clock frequency, all modules will deliver the same current (within component tolerances). The single intelligent module in the array determines the transient response, which does not change as modules are added. Booster modules require only one connection between units when their outputs are connected; no trimming, adjustments, or external components are required to achieve load sharing. The load sharing is dynamic and usually guaranteed to be within five percent.

It is important to remember that when using boosters, the input voltage, output voltage, and output power of the boosters must be the same as the driver.

The advantages of driver / booster arrays are that they have only a single control loop so there are no loop-within-a-loop stability issues, and they have excellent transient response. However, this arrangement is not fault tolerant. If the driver module fails, the array will fail to maintain its output voltage.

Analog Current-Share Control: Analog current-share control, typical of PWM type converters, involves paralleling two or more identical modules, each containing intelligence. The circuit actively adjusts the output voltage of each supply so that the multiple supplies deliver equal currents. This method, however, has a number of disadvantages. Each converter in the array has its own voltage regulation loop, and each requires a current sensing device and current control loop.

Analog current-share control supports a level of redundancy, but it is susceptible to single-point failures within the current-share bus that can at best, defeat current sharing, and at worst, destroy every module in the array. The major reason for this is the single-wire galvanic connection between modules.

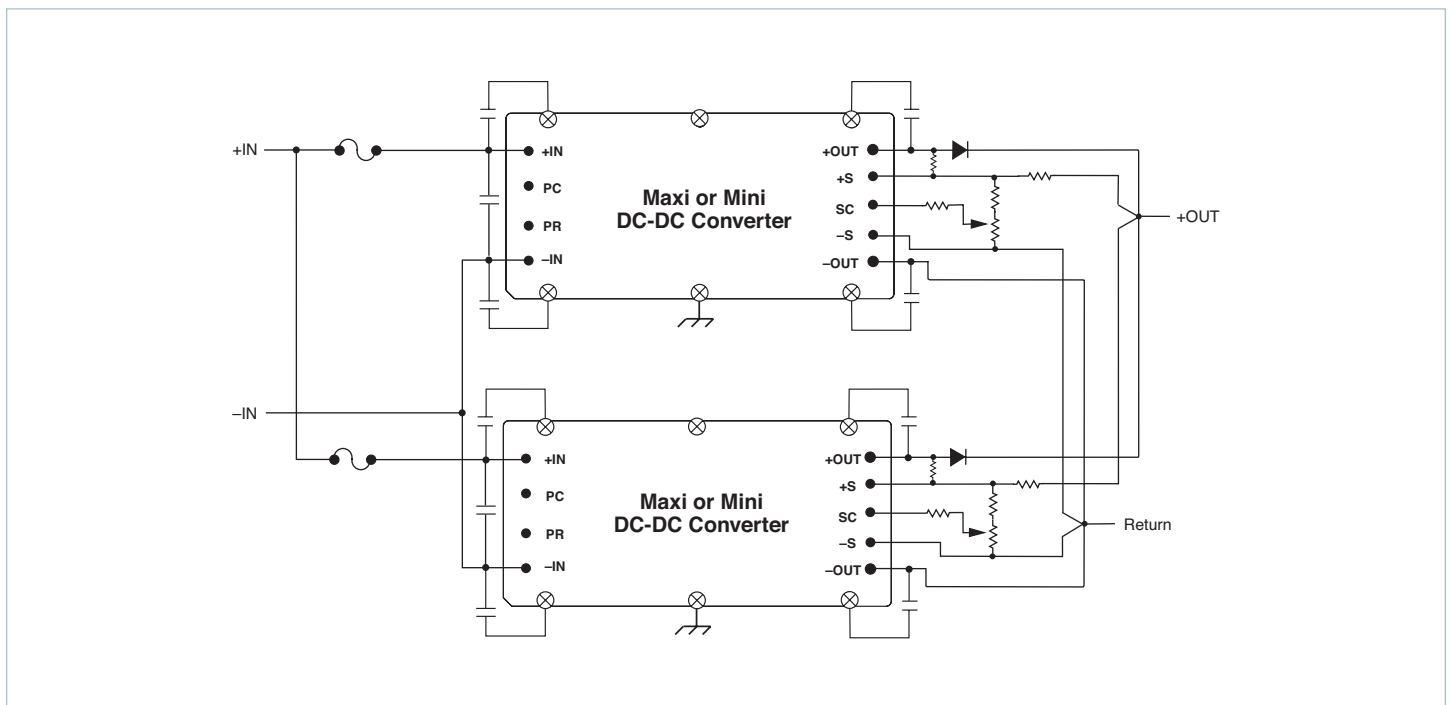

Figure 5.1 — The droop-share method artificially increases the output impedance to force the currents to be equal

Current Sharing in Fault Tolerant Arrays

Current sharing is an essential element in fault-tolerant arrays, and regardless of the approach, there is an inherent additional cost incurred by the addition of at least one redundant converter or supply.

Most applications today that require fault tolerance or redundancy also require Hot-Swap capability to ensure continuous system operation. Hot-swappable cards must be designed so that the operator cannot come in contact with dangerous potentials, currents or thermal hazards. It is also essential that when a module fails, the failure is detected and identified by an alarm or notice to provide service. A Hot-Swap system must ensure that during swap out there is minimal disturbance of the power bus. Specifically, the affected voltage bus must not drop enough to cause errors in the system, either on the input bus or the output bus.

N+1 Redundancy: A power supply failure can cripple an entire system, so a redundant converter or supply can be added to ensure that, in the event of a failure, the system will continue to operate. Adding an extra module (N+1) to a group of paralleled modules will significantly increase reliability with only a modest increase in cost.

How redundant converters are implemented is determined in part by the available space and cost requirements. Two 500W Maxi modules, for example, could be used to provide a 1kW output with an additional 500W module for 2+1 redundancy a total of 1.5kW in a volume of about 16.5in³ [270cm³]. Four 200W half-size modules might be used instead with a fifth 200W module for 4+1 redundancy, a total of 1kW and 14in³ [229cm³]. Although the second solution uses less space, it increases the accumulated failure rate because it employs more converters, more ORing diodes, more monitoring circuitry, and more assembly.

ORing diodes may be inserted in series with the +Output of each module in a N+1 array to provide output fault tolerance (Figure 5.1). They are important in a redundant power system to maintain fault isolation. Without them, a short-circuit failure in the output of one converter could bring down the entire array. As well, fusing the input of each converter prevents a converter input short from compromising the entire array.

ORing diodes, however, add losses to the power system, reducing overall efficiency (and, potentially, decreasing reliability). To ameliorate this negative effect on efficiency, ORing diodes should run hot, thereby reducing forward voltage drop and improving system efficiency. Reverse leakage current will be an issue only if the output of a converter shorts and the diode is reverse biased. This is an important consideration with regard to operating temperature.

Current sharing, required to ensure system reliability, can be implemented by a multiplicity of methods. Figure 5.1, shown earlier as an example of the droop-share method, is also an example of N+1 redundancy using ORing diodes.

Synchronous Current Sharing: Synchronous current sharing is available with Maxi, Mini, Micro converters – converters that use the zero-current-switching and zero-voltage-switching topology. Each module has the capability to assume control of the array, that is, they constitute a democratic array. The module that assumes command transmits a pulse on the parallel bus to which all other modules on the bus synchronize.

The converters use this pulse as a current-sharing signal for power expansion and fault-tolerant applications. The pulsed signal on the parallel bus simplifies current-sharing control by synchronizing the high-frequency switching of each converter. The parallel pin is a bi-directional port on each module used to transmit and receive information between modules. If the lead module relinquishes control, another module in the array will transparently take command with little or no perturbation of the output bus. A pulsed signal gives designers the option to use capacitors (Figure 5.2) or transformers between parallel pins, providing DC-blocked coupling. Such coupling prevents certain failure modes internal to a single module from affecting the other modules in the array, thus providing an increased level of fault tolerance.

Use of a current-share bus transformer (Figure 5.3) enables arrays of Maxi, Mini, Micro converters to current share when they are widely separated or operated from independent sources. Since the current-share signal is a pulsed signal, it can be transformer coupled. Transformer coupling this pulsed signal provides a high level of common-mode noise immunity while maintaining SELV isolation from the primary source. This is especially useful when board-to-board load sharing is required in redundant applications.

Synchronous current sharing eliminates the need for current-sensing or current-measuring devices on each module, and load regulation is not compromised. Additional advantages of the synchronous current-sharing architecture includes excellent transient response, no loop-within-a-loop control problems and a high degree of immunity from system noise. The availability of synchronous current sharing in democratically controlled arrays offers power architects new opportunities to achieve simple, non-dissipative current-share control. It provides options that simplify current sharing and eliminates the tradeoffs – such as the need to sense the current from each individual module and adjust each control voltage – as is the case with other current-sharing methods.

The synchronous current-sharing method applies to quasi-resonant, frequency-modulated converters with the necessary intelligence, such as the Vicor Maxi, Mini, Micro Family of high-density DC-DC converters, where the energy per pulse is fixed.

Finally, no matter what method is used, current sharing reduces thermal problems, improves transient response and helps extend the lifetimes of all modules in an array. Nevertheless, all current-sharing schemes require careful attention to electrical and mechanical design to operate effectively.

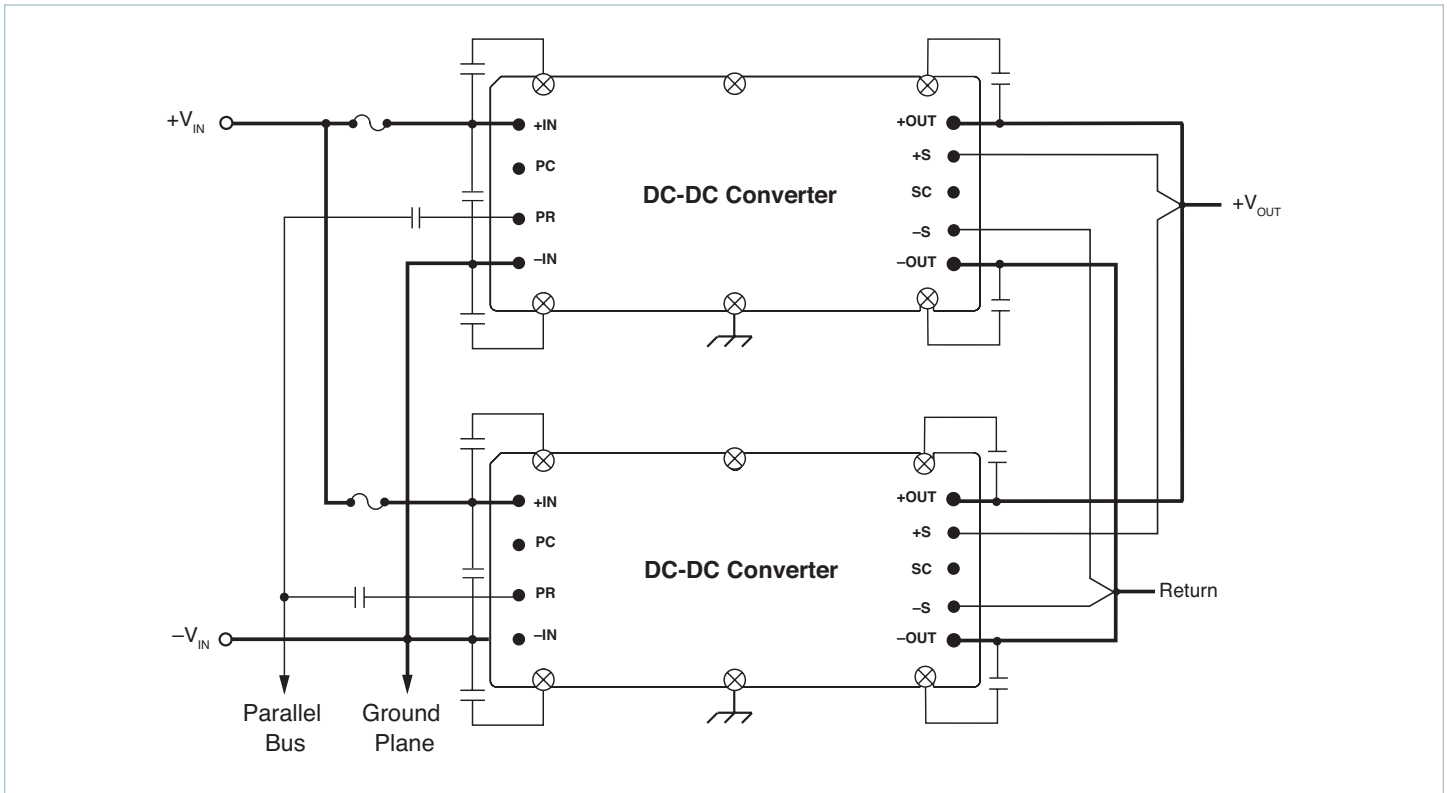

Figure 5.2 — Synchronous power architecture simplifies current-sharing control and enhances fault tolerance

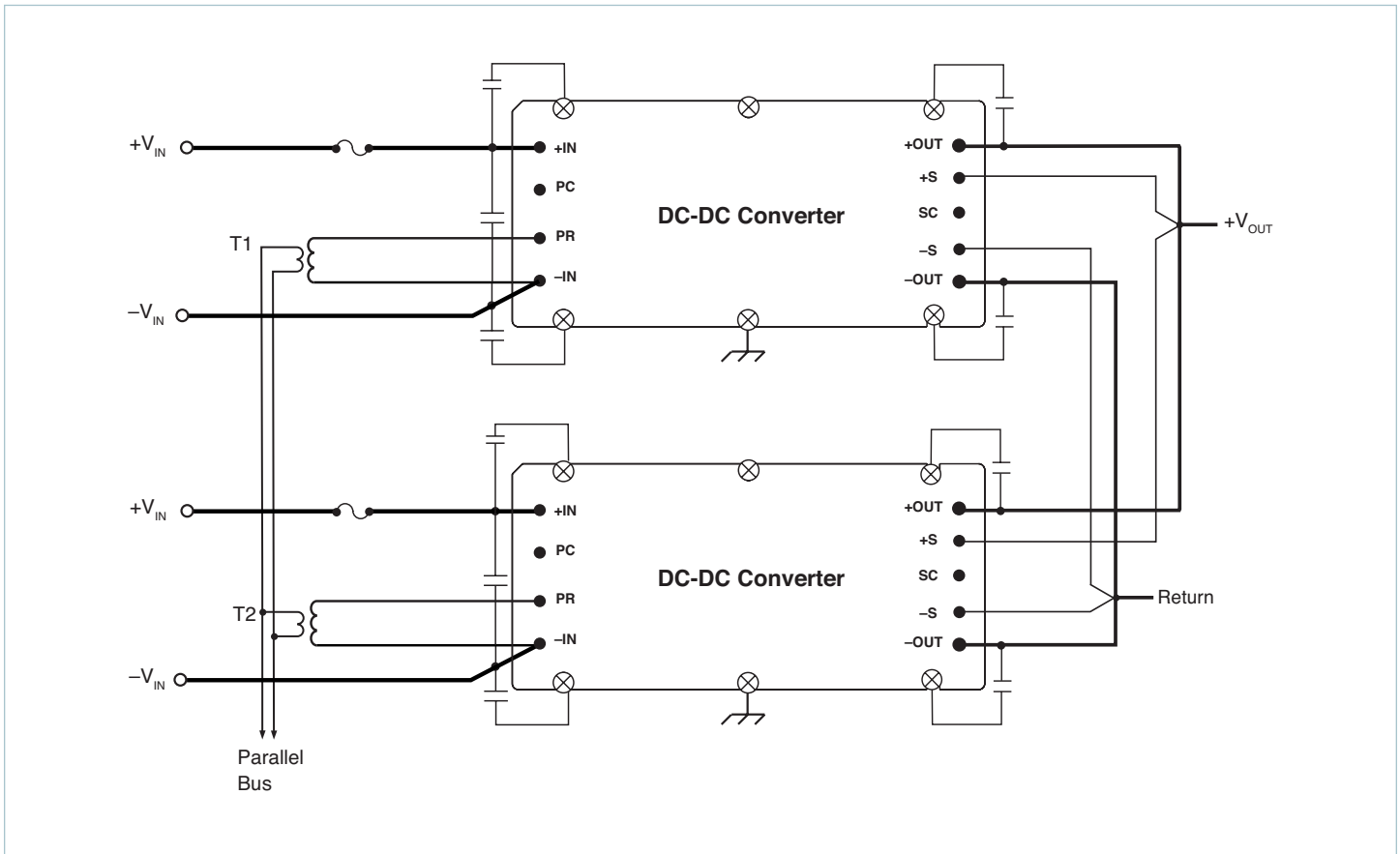

Figure 5.3 — Transformer-coupled interface provides load sharing and SELV isolation from the primary source