

### OVERVIEW

The VI-/MI-200 Family of DC-DC converters are available as Driver or Booster modules. The Driver can be used as a stand alone module, or in multi-kilowatt arrays by adding parallel Boosters. Booster modules do not contain feedback or control circuitry, so it is necessary to connect the Booster GATE IN pin to the preceding Driver or Booster GATE OUT, to synchronize operation. Drivers and Boosters have identical power trains, although Drivers close the voltage loop internally while Boosters do not.

The concept behind Driver / Booster operation is that two or more ZCS power trains driven at the same frequency will inherently load-share if their inputs and outputs are tied together. Slaved modules require only one connection between units when their outputs are connected together; no trimming, adjustments or external components are required to achieve load sharing. The load sharing is dynamic and typically within 5%.

For additional information, refer to *Electrical Considerations – High Power Arrays in the [Module Do’s and Don’ts](#)*. (Section 3)

**IMPORTANT:** It is important to remember that when using Boosters, the input voltage, output voltage and output power of the Boosters must be the same as the Driver.

Whenever power supplies or converters are operated in a parallel configuration—for higher output power, fault tolerance, or both—current sharing is an important

consideration. Most current-sharing schemes employed with power converters involve analog approaches. One analog method artificially increases the output impedance of the converter modules, while another actually senses the output current of each module and forces all of the currents to be equal by feedback control.

Synchronous current sharing offers an alternative to analog techniques. In a synchronous scheme, there is no need for a current-sensing or current-measuring device on each module. Nor is there a need to artificially increase output impedance, which compromises load regulation.

There are advantages and disadvantages associated with each approach to current sharing. In choosing the best approach for a given application, designers should be aware of the tradeoffs as well as tips for implementing a successful design.

Most paralleled power components, such as transistors, rectifiers, power conversion modules, and offline power supplies, will not inherently share the load. With power converters, one or more of the converters will try to assume a disproportionate or excessive fraction of the load unless forced current-sharing control is designed into the system.

One converter, typically the one with the highest output voltage, may deliver current up to its current limit setting, which is beyond its rated maximum. Then, the voltage will drop to the point where another converter in the array—the one with the next highest voltage—will begin to deliver current. All of the converters in an array may

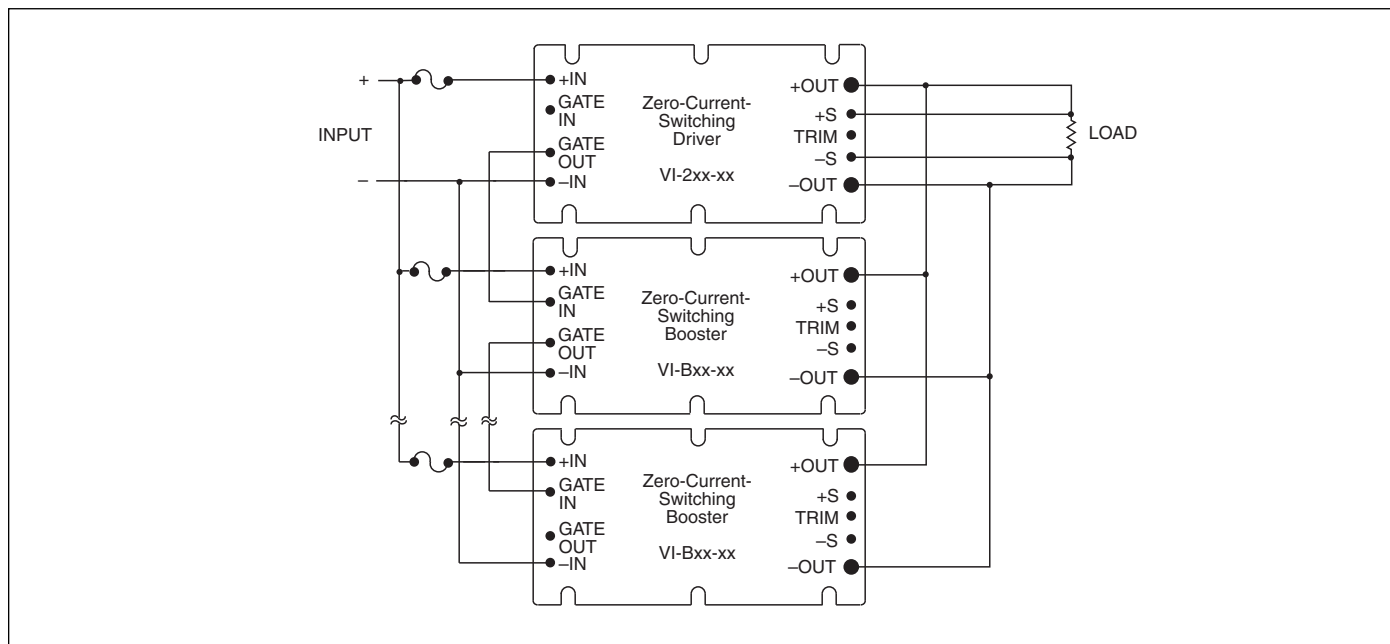

Figure 8-1 — Parallel array

deliver some current, but the load will be shared unequally. With built-in current limiting, one or more of the converters will deliver current up to the current limit (generally 15 or 20% above the module's rated maximum), while other converters in the array supply just a fraction of load.

Consider a situation where one module in a two-module array is providing all of the load. If it fails, the load on the second module must go from no load to full load. During that time, the output voltage is likely to droop temporarily. This could result in system problems, including shutdown or reset.

On the other hand, if both modules were sharing the load and one failed, the surviving module would experience a much less severe transient (one-half to full load). Also, the output voltage would be likely to experience no more than a slight momentary droop. The dynamic response characteristic of all forward converters, resonant or pulse-width modulated, is degraded when the load is stepped from zero (no load) where the output inductor current is discontinuous.

In the same two-module array example, the module carrying all of the load also is generating all of the heat. That results in a much lower mean time between failure for that module. An often-quoted rule of thumb says that for each 10°C increase in operating temperature, average component life is cut in half.

In a current-sharing system, the converters or supplies all run at the same temperature. This temperature is lower than that of the hot-running (heavily loaded) modules in a system without current sharing. Furthermore, same-temperature operation means that all of the modules in a current-sharing arrangement age equally.

Current sharing, then, is important because it improves system performance. It optimizes transient and dynamic response and minimizes thermal problems, which improves reliability and helps extend the lifetimes of all of the modules in an array. Current sharing is an essential ingredient in most systems that use multiple power supplies or converters to achieve higher output power or fault tolerance.

When parallel supplies or converters are used to increase power, current sharing is achieved through a number of approaches. One scheme simply adds resistance in series with the load. A more practical variant of that is the "droop-share" method, which actively causes the output voltage to drop in response to increasing load. Nevertheless, the two most commonly used approaches to paralleling converters for power expansion are Driver / Booster arrays and analog current-sharing control. They appear to be similar, but the implementation of each is quite different.

Driver / Booster arrays usually contain one intelligent module or Driver, and one or more power-train-only modules or Boosters. Analog current-sharing control involves paralleling two or more identical modules, each containing intelligence.

One of the common methods of forcing load sharing in an array of parallel converters is to sense the output current of each converter and compare it to the average current. Then, the output of a given converter is adjusted so that its contribution is equal to the average. This is usually accomplished by current-sense resistors in series with the load, a sensing amplifier for each converter module, and a summing amplifier. Load sharing is accomplished by actively trimming the output voltage using TRIM or SENSE pins.

Occasionally, a designer is tempted to avoid the expense of a current-sense resistor by using the IR drops in the wire as a means of sensing the current. Unfortunately, there are a number of negative issues associated with that idea. First of all, there's the temperature coefficient of copper. As the wire heats up, its resistance increases, negating its value as a stable current-sensing device. Second, there are oxidation and corrosion issues, which also cause parametric changes. Consequently, a high-precision current-sensing device, such as a precision resistor, is a must.

The resistor values typically range from a few milliohms up to about 100 mΩ, depending on the power level or current range of operation. Selecting the right value requires a tradeoff between power dissipation and sensitivity (signal-to-noise ratio or noise immunity). The larger the resistor value, the better the noise immunity—and the greater the power dissipation.

Determining the size of the resistor needed to generate a signal above the noise can be a bit tricky. Another potential pitfall with this (or, for that matter, any other) approach is the need for good electrical and mechanical design and layout. This requires adequate trace widths, minimized trace lengths, and decoupling to reduce noise. An experienced designer should have no difficulty with this, but it is an area rich with opportunities for error.

The droop-share method artificially increases the output impedance to force the currents to be equal. It's accomplished by injecting an error signal into the control loop of the converter, causing the output voltage to vary as a function of load current. As load current increases, output voltage decreases. All of the modules will deliver approximately the same current because they are all being summed into one node.

If one supply is delivering more current than another supply, its output voltage will be slightly forced down so

that it will be delivering equal current for an equal voltage at the summing node. A simple implementation of the droop-share scheme uses the voltage dropped across an ORing diode, which is proportional to current, to adjust the output voltage of the associated converter. (Figure 8–2)

Droop share has advantages and disadvantages. One of the advantages is that it can work with any topology. It's also fairly simple and inexpensive to implement. Though, a major drawback is that it requires that the current be sensed. A current-sensing device is needed in each of the converters or power supplies. Additionally, a small penalty is paid in load regulation, though in many applications this isn't an issue.

In general, mixing and matching converters isn't recommended—especially those with incompatible current-sharing schemes. The droop-share method, however, is more forgiving in this regard than any of the other techniques. With a little external circuitry, current sharing can be achieved using arrays constructed from different converter models or even from different suppliers.

Most systems can employ the Driver / Booster (or master / slave) array for increased power. (Figure 8–3) The Driver is used to set and control output voltage, while Booster modules, as slaves to the master, are used to extend output power to meet system requirements.

Driver / Booster arrays of quasi-resonant converters with identical power trains inherently current share because the per-pulse energy of each converter is the same. If the inputs and outputs are tied together and the units operate at the same frequency, all modules will deliver equal current (within component tolerances).

The single intelligent module in the array determines the transient response, which does not change as modules are added. Slaved modules require only one connection between units when their outputs are connected. No trimming, adjustments, or external components are required to achieve load sharing. The load sharing is dynamic and usually guaranteed within 5%. It's important to remember that when using Boosters, the input and output voltage and output power specifications of the Boosters must be the same as the Driver.

Driver / Booster arrays have two advantages. They have only a single control loop, so there are no loop-within-a-loop stability issues. And, they have excellent transient response. However, this arrangement isn't fault tolerant. If the Driver module fails, the array won't maintain its output voltage.

Analog current-sharing control involves paralleling two or more identical modules, each containing intelligence. The circuit actively adjusts the output voltage of each supply so the multiple supplies deliver equal currents. This method, though, has a number of disadvantages. Each converter in the array has its own voltage regulation loop, and each requires a current-sensing device and current-control loop.

Analog current-sharing control does support a level of redundancy. But it's susceptible to single-point failures within the current-sharing bus that at best can defeat current sharing, and at worst can destroy every module in the array. The major reason for this is the single-wire galvanic connection between modules.

Current sharing is an essential element in fault-tolerant arrays. Yet regardless of the approach, there is an inherent

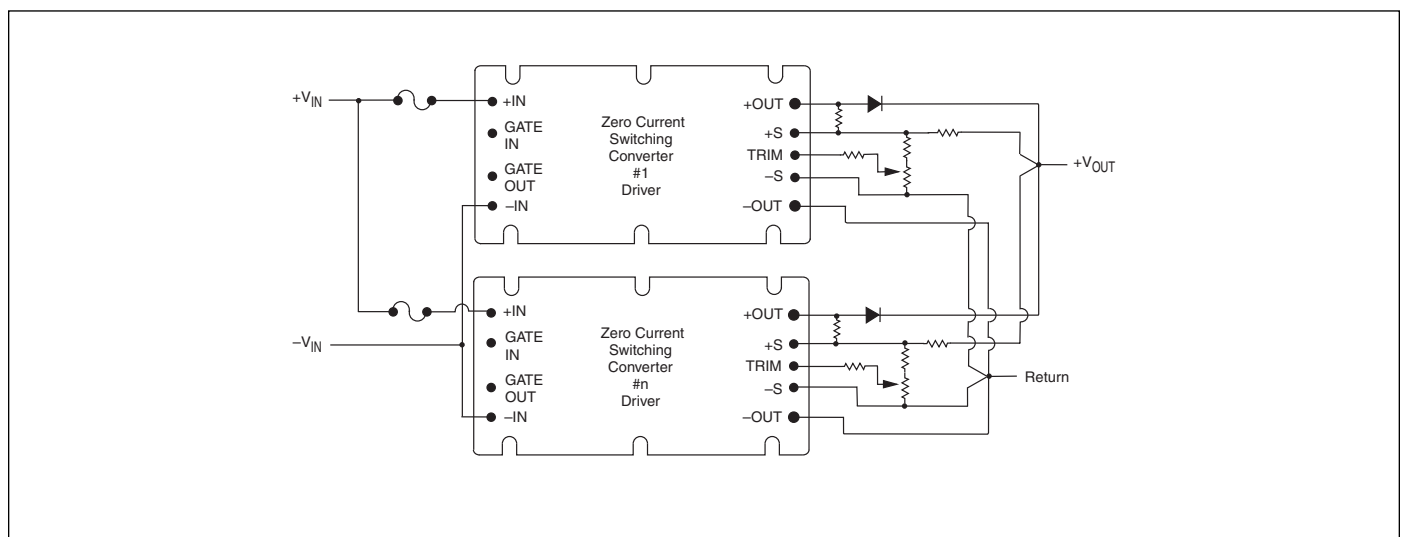

**Figure 8–2** — Droop-share current sharing artificially increases converter output impedance to force the currents to be equal. Diodes on the output of each converter provide current sensing and fault protection.

cost incurred by the addition of at least one redundant converter or supply.

Incidentally, most applications today that require fault tolerance or redundancy also require Hot-Swap capability to ensure continuous system operation. Hot-swappable cards must be designed so the operator won't come in contact with dangerous potentials and currents.

It's also essential that when a module fails, the failure is detected and identified by an alarm or notice to provide service. A Hot-Swap system must ensure that during swap-out, there is minimal disturbance of the power bus. Specifically, the affected voltage bus must not drop enough to cause errors in the system, either on the input bus or the output bus.

A power-supply failure can cripple an entire system, so the addition of a redundant converter or supply is often justified by the need to keep the system operating. Adding an extra module (N+1) to a group of paralleled modules will significantly increase reliability with only a modest increase in cost.

The implementation of redundant converters is determined in part by the available space and cost requirements. For example, two 200 W full-size modules

could be used to provide a 400 W output with an additional 200 W module for 2+1 redundancy (a total of 600 W in a volume of about 16.5 in<sup>3</sup>).

Alternatively, four 100 W half-size modules might be used with a fifth 100 W module to provide 4+1 redundancy (a total of 500 W and 14 in<sup>3</sup>). Although the second solution uses less space, it increases the accumulated failure rate because it employs more converters, more ORing diodes, more monitoring circuitry, and more assembly.

ORing diodes may be inserted in series with the output of each module in an N+1 array to provide output fault tolerance. (Figure 8–2) They're important in a redundant power system to maintain fault isolation. Without them, a short-circuit failure in the output of one converter could bring down the entire array.

But ORing diodes add losses to the power system, reducing overall efficiency and decreasing reliability. To ameliorate the negative effect on efficiency, ORing diodes should run hot, thereby reducing forward voltage drop and increasing efficiency. Reverse leakage current will be an issue only if the output of a converter shorts and the diode is reverse biased. This is an important consideration with regard to operating temperature.

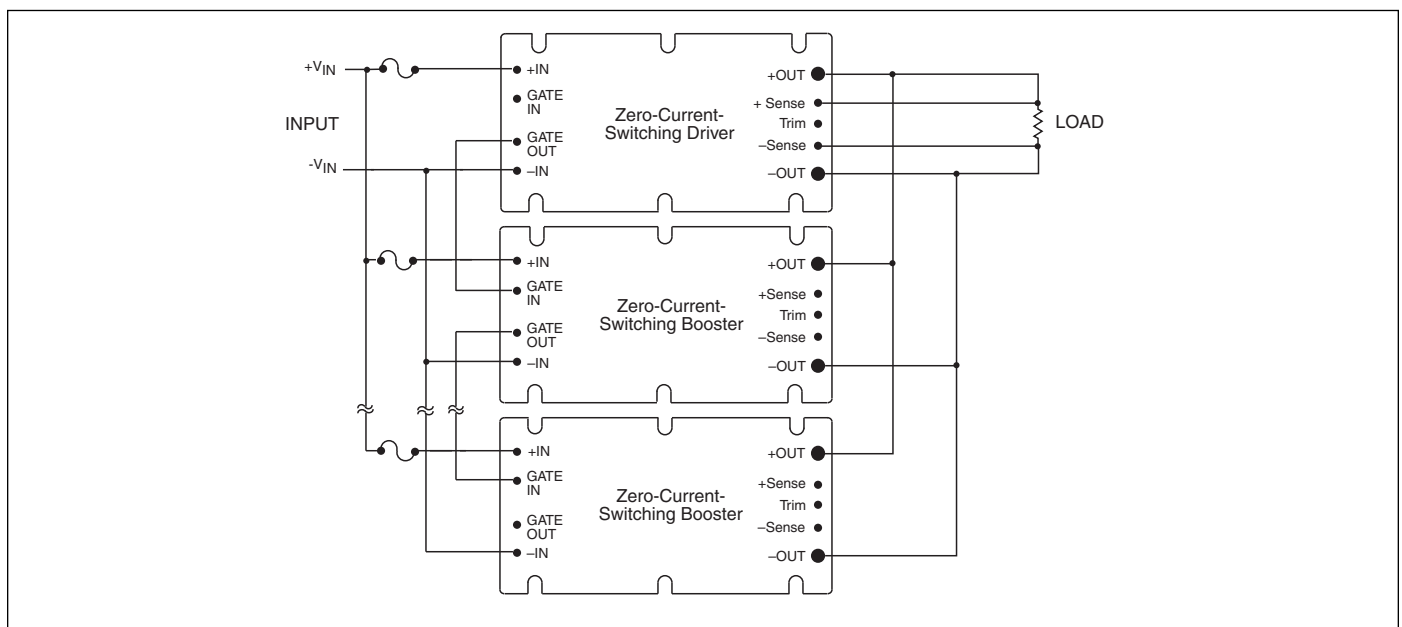

**Figure 8–3** — Most converters can use the Driver / Booster array to increase output power. Driver / Booster arrays usually contain one intelligent module or Driver, and one or more power-train-only modules or Boosters.