



Data Sheet

VI-J00, VE-J00

Half Brick

DC-DC Converters

25 to 100 Watts



Features

- RoHS compliant (VE versions)
- Up to 50 Watts per cubic inch
- cULus, cTUVus
- CE Marked
- Up to 90% efficiency
- Size: 2.28" x 2.4" x 0.5" (57,9 x 61,0 x 12,7)
- Remote sense and current limit
- Logic disable
- Wide range output adjust
- ZCS power architecture
- Low noise FM control
- Isolated output

Product Highlights

The VI-J00 MiniMod family established a new standard in component-level DC-DC converters. This “junior” size complement to the higher power VI-200 family offers up to 100 W of isolated and regulated power in a board mounted package. With thousands of input/output/power combinations, and with a maximum operating temperature rating of 100°C, the MiniMod provides nearly unlimited flexibility for power system designers to meet demanding time to market requirements.

Utilizing Vicor’s “zero-current-switching” forward converter technology, proven by an installed base of over 8 million units, the MiniMod family combines state of the art power density with the efficiency, low noise and reliability required by next generation power systems.

Part Numbering

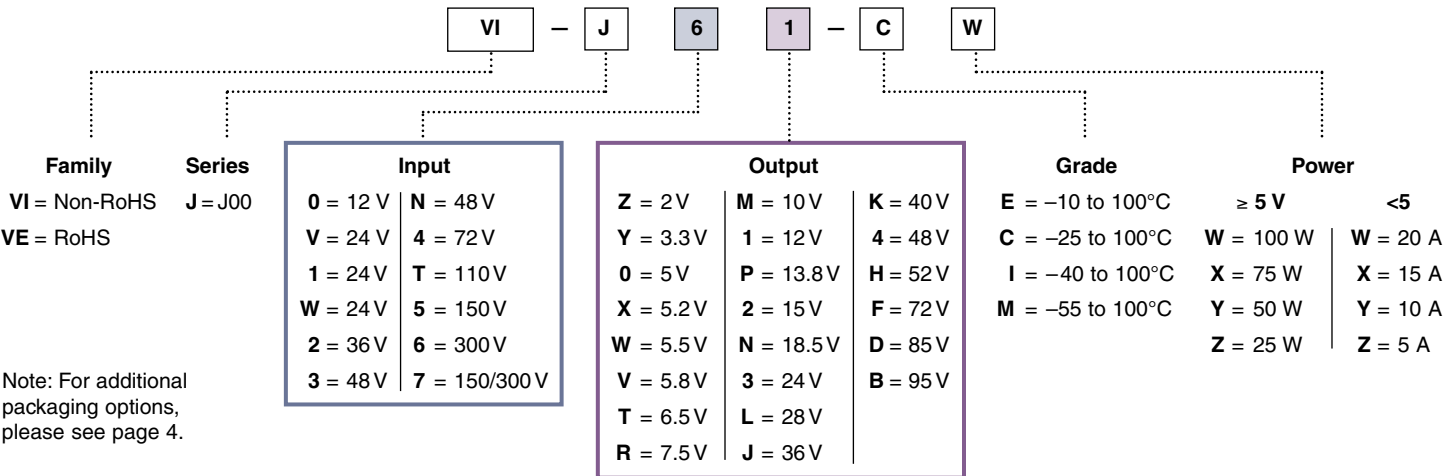

Maximum Power Available for VI-Jxx-xx

Input		Output																						
Voltage Nom. (Range)	Low Line 75% Max Power	Transient ^[a]	Vin Designators	Vout Designators																				
				2	3.3	5	5.2	5.5	5.8	6.5	7.5	10	12	13.8	15	18.5	24	28	36	40	48	52	72	85
12 (10-20)	n/a	22	0	X	X	Y	Y	Y	Y	Y	Y	Y	X	X	X	X	X	X	X	X	X	X	X	X
24 (10-36)	n/a	n/a	V	--	Y	Y	Y	Y	Y	Y	Y	Y	Y	Y	Y	Y	Y	Y	Y	Y	--	--	--	--
24 (21-32)	18	36	1	W	W	W	W	W	W	X	X	W	W	W	W	W	W	W	W	W	W	W	W	W
24 (18-36)	n/a	n/a	W	W	W	W	W	W	X	X	W	W	W	W	W	W	W	W	W	W	W	W	W	W
36 (21-56)	18	60	2	Y	Y	Y	Y	Y	Y	Y	Y	X	X	X	X	X	X	X	X	X	--	--	--	--
48 (42-60)	36	72	3	W	W	W	W	W	W	X	X	W	W	W	W	W	W	W	W	W	W	W	W	W
48 (36-76)	n/a	n/a	N	W	W	X	X	X	X	X	X	W	W	W	W	W	W	W	W	W	W	W	W	W
72 (55-100)	45	110	4	W	W	W	W	W	W	X	X	W	W	W	W	W	W	W	W	W	W	W	W	W
110 (66-160)	n/a	n/a	T	W	W	X	X	X	X	X	X	W	W	W	W	W	W	W	W	W	W	W	W	--
150 (100-200)	85	215	5	W	W	W	W	W	W	X	X	W	W	W	W	W	W	W	W	W	W	W	W	W
150 (100-375)	n/a	n/a	7	Y	Y	Y	Y	Y	Y	Y	Y	X	X	X	X	X	X	X	X	X	X	X	X	--
300 (200-400)	170	425	6	W	W	W	W	W	W	X	X	W	W	W	W	W	W	W	W	W	W	W	W	W

^[a] Transient voltage for 1 second.

CONVERTER SPECIFICATIONS

(typical at $T_{BP} = 25^{\circ}\text{C}$, nominal line and 75% load, unless otherwise specified)

INPUT SPECIFICATIONS

Parameter	VI-J00 E-Grade			VI-J00 C-, I-, M-Grade			Units	Test Conditions
	Min	Typ	Max	Min	Typ	Max		
Inrush charge		60×10^{-6}		60×10^{-6}	100×10^{-6}		Coulombs	Nominal line
Input reflected ripple current – pp		10%		10%			I_{IN}	Nominal line, full load
Input ripple rejection		$25 + 20 \text{Log}\left(\frac{V_{in}}{V_{out}}\right)$		$30 + 20 \text{Log}\left(\frac{V_{in}}{V_{out}}\right)$			dB	120 Hz, nominal line
				$20 + 20 \text{Log}\left(\frac{V_{in}}{V_{out}}\right)$				2400 Hz, nominal line
No load power dissipation		1.35	2	1.35	2		Watts	

OUTPUT CHARACTERISTICS

Parameter	VI-J00 E-Grade			VI-J00 C-, I-, M-Grade			Units	Test Conditions
	Min	Typ	Max	Min	Typ	Max		
Setpoint accuracy		1%	2%	0.5%	1%		V_{NOM}	
Load/line regulation			0.5%	0.05%	0.2%		V_{NOM}	LL to HL, 10% to Full Load
			1%	0.2%	0.5%		V_{NOM}	LL to HL, No Load to 10%
Output temperature drift		0.02		0.01	0.02		% / $^{\circ}\text{C}$	Over rated temperature
Long term drift		0.02		0.02			%/1K hours	
Output ripple – pp:			200	100	150		mV	20 MHz bandwidth
	2 V, 3.3 V						V_{NOM}	20 MHz bandwidth
	5 V		5%	2%	3%		V_{NOM}	20 MHz bandwidth
10 – 95 V		3%		0.75%	1.5%		V_{NOM}	20 MHz bandwidth
Trim range ^[a]	50%		110%	50%	110%		V_{NOM}	
Total remote sense compensation	0.5			0.5			Volts	0.25 V max. neg. leg
Current limit	105%		135%	105%	125%		$I_{full\ load}$	Automatic restart
Short circuit current	105%		140%	105%	130%		$I_{full\ load}$	Automatic restart

^[a] 10 V, 12 V, 13.8 V, 15 V outputs, or “V” input range have standard trim range $\pm 10\%$. Consult factory for wider trim range.

95 V output –50 + 0% trim range.

CONTROL PIN SPECIFICATIONS

Parameter	VI-J00 E-Grade			VI-J00 C-, I-, M-Grade			Units	Test Conditions
	Min	Typ	Max	Min	Typ	Max		
Gate out impedance		50		50			Ohms	
Gate in impedance		1000		1000			Ohms	
Gate in high threshold		6			6		Volts	Use open collector
Gate in low threshold	0.65			0.65			Volts	
Gate in low current			6		6		mA	

CONVERTER SPECIFICATIONS

(typical at $T_{BP} = 25^{\circ}\text{C}$, nominal line and 75% load, unless otherwise specified)

■ DIELECTRIC WITHSTAND CHARACTERISTICS

Parameter	VI-J00 E-Grade			VI-J00 C-, I-, M-Grade			Units	Test Conditions
	Min	Typ	Max	Min	Typ	Max		
Input to output	3,000			3,000			V _{RMS}	Baseplate earthed
Output to baseplate	500			500			V _{RMS}	
Input to baseplate	1,500			1,500			V _{RMS}	

■ THERMAL CHARACTERISTICS

Parameter	VI-J00 E-Grade			VI-J00 C-, I-, M-Grade			Units	Test Conditions
	Min	Typ	Max	Min	Typ	Max		
Efficiency		78 – 88%			80 – 90%			
Baseplate to sink		0.14			0.14		$^{\circ}\text{C}/\text{Watt}$	With Vicor P/N 20267

■ MECHANICAL SPECIFICATIONS

Parameter	VI-J00 E-, C-Grade			VI-J00 I-, M-Grade			Units	Test Conditions
	Min	Typ	Max	Min	Typ	Max		
Weight	2.9	3.2	3.6	3.4	3.8	4.1	Ounces	
	82.8	92	101.2	96.3	107	117.7	Grams	

■ PRODUCT GRADE TEMPERATURES

Parameter	Storage	Operating	Units	Notes
E	-20 to +105	-10 to + 100	$^{\circ}\text{C}$	
C	-40 to +105	-25 to + 100	$^{\circ}\text{C}$	
I	-55 to +105	-40 to + 100	$^{\circ}\text{C}$	
M	-65 to +105	-55 to + 100	$^{\circ}\text{C}$	

MECHANICAL DRAWING

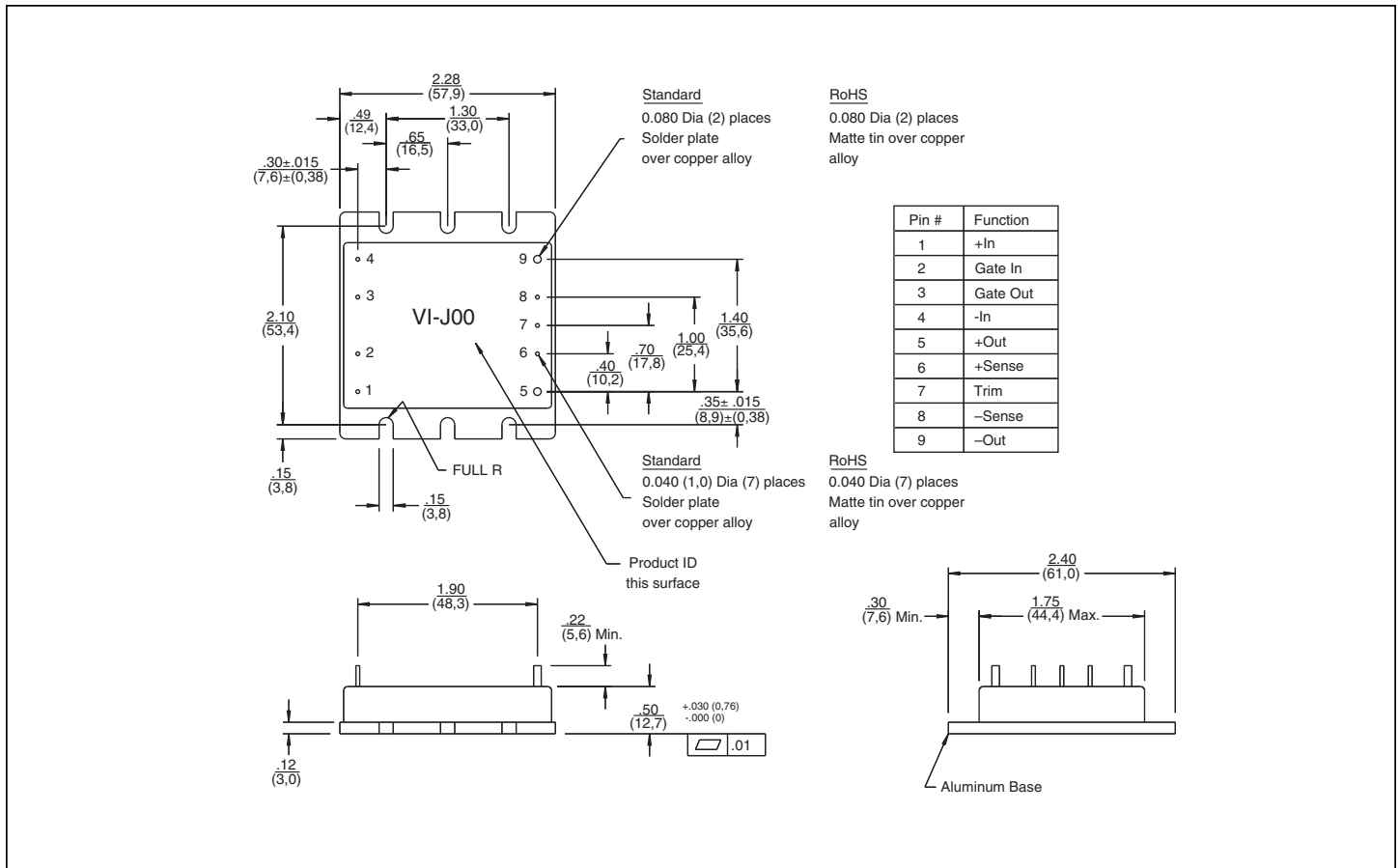

PACKAGING OPTIONS

Flangeless package



2.28"L x 1.80"W x 0.50"H
(57,9 x 45,7 x 12,7 mm)

To order the SlimMod configuration add the suffix "-S" to the standard module part number.

Qty (2) grounding clips are included with each SlimMod P/N 32187

Flangeless package with integral heat sink



Longitudinal, 0.25"(6.35 mm) fins — add suffix "-F1"
Longitudinal, 0.50"(12.7 mm) fins — add suffix "-F2"



Transverse, 0.25"(6.35 mm) fins — add suffix "-F3"
Transverse, 0.50"(12.7 mm) fins — add suffix "-F4"

Available with longitudinal or transverse fins of 0.25"(6.35 mm) or 0.50"(12.7 mm) height. Add the appropriate suffix to the module part number.

Qty (4) grounding clips are included with each FinMod
F1, F2 P/N 32185
F3, F4 P/N 32186

MegaMod Jr.

Chassis mount alternatives, one, two, or three outputs: up to 300 W



1 up - 2.58" x 2.5" x 0.62" (65,5 x 63,5 x 15,7 mm)
2 up - 2.58" x 4.9" x 0.62" (65,5 x 124,5 x 15,7 mm)
3 up - 2.58" x 7.3" x 0.62" (65,5 x 185,4 x 15,7 mm)

BusMod



2.28"L x 2.40"W x 1.08"H
(57,9 x 61,0 x 27,4 mm)

To order the BusMod fully assembled, add suffix "-B1" to the standard module part number.

To order the BusMod separately:
Half-sized BusMod — P/N 18952

[See BusMod Mechanical Drawings for more details.](#)

Warranty

Vicor products are guaranteed for two years from date of shipment against defects in material or workmanship when in normal use and service. This warranty does not extend to products subjected to misuse, accident, or improper application or maintenance. Vicor shall not be liable for collateral or consequential damage. This warranty is extended to the original purchaser only.

EXCEPT FOR THE FOREGOING EXPRESS WARRANTY, VICOR MAKES NO WARRANTY, EXPRESS OR IMPLIED, INCLUDING, BUT NOT LIMITED TO, THE WARRANTY OF MERCHANTABILITY OR FITNESS FOR A PARTICULAR PURPOSE.

Vicor will repair or replace defective products in accordance with its own best judgement. For service under this warranty, the buyer must contact Vicor to obtain a Return Material Authorization (RMA) number and shipping instructions. Products returned without prior authorization will be returned to the buyer. The buyer will pay all charges incurred in returning the product to the factory. Vicor will pay all reshipment charges if the product was defective within the terms of this warranty.

Information published by Vicor has been carefully checked and is believed to be accurate; however, no responsibility is assumed for inaccuracies. Vicor reserves the right to make changes to any products without further notice to improve reliability, function, or design. Vicor does not assume any liability arising out of the application or use of any product or circuit; neither does it convey any license under its patent rights nor the rights of others. Vicor general policy does not recommend the use of its components in life support applications wherein a failure or malfunction may directly threaten life or injury. Per Vicor Terms and Conditions of Sale, the user of Vicor components in life support applications assumes all risks of such use and indemnifies Vicor against all damages.

Vicor's comprehensive line of power solutions includes high density AC-DC and DC-DC modules and accessory components, fully configurable AC-DC and DC-DC power supplies, and complete custom power systems.

Information furnished by Vicor is believed to be accurate and reliable. However, no responsibility is assumed by Vicor for its use. Vicor components are not designed to be used in applications, such as life support systems, wherein a failure or malfunction could result in injury or death. All sales are subject to Vicor's Terms and Conditions of Sale, which are available upon request.

Specifications are subject to change without notice.

Intellectual Property Notice

Vicor and its subsidiaries own Intellectual Property (including issued U.S. and Foreign Patents and pending patent applications) relating to the products described in this data sheet. Interested parties should contact Vicor's Intellectual Property Department.

Vicor Corporation
25 Frontage Road
Andover, MA, USA 01810
Tel: 800-735-6200
Fax: 978-475-6715

email

Customer Service: custserv@vicorpower.com
Technical Support: apps@vicorpower.com