

For 24/28V and 48/60V BUS Applications

Description

The QPI family of EMI input filters provide conducted common-mode (CM) and differential-mode (DM) attenuation from 150kHz to 30MHz (CISPR22 range). Proprietary active-filtering circuits provide superior attenuation at low frequencies intended to support EN Class B limits, including PICMG3.0 for ATCA boards.

In comparison to passive solutions, the use of active filtering reduces the volume of the common-mode choke, providing a low-profile, surface-mount device. Smaller size saves valuable board real estate and the reduced height enhances airflow in blade applications.



Features & Benefits

- Up to 65dB CM attenuation at 250kHz
- Up to 80dB DM attenuation at 250kHz
- Efficiency: >99% at full load
- High-density, low-profile LGA package
- Saves up to 50% board space vs. standard filters
- Compatible with most DC-DC converters
- -40 to +100°C PCB temperature
- TÜV approved

Applications

- PICMG® 3.0 ATCA applications
- Networking & communications
- Fan-tray assemblies
- Telecom and broadcast
- Industrial
- Military (MQPI)

Part Numbering

Part Number (-01 = Open Frame)	Input Voltage (V)	Current Rating (A)	Test Freq. (kHz)	CM Attenuation (dB)	DM Attenuation (dB)	Hipot (V)	Package (mm)
MQPI-18LP	05 – 50	7	1,000	45	75	1,500	LGA 25 x 12.4 x 4.5
MQPI-18LP-01	05 – 50	7	1,000	45	75	1,500	LGA Open Frame 25 x 12.4 x 4.5
QPI-3LZ	10 – 40	7	250	65	80	707	LGA 25 x 25 x 4.5
QPI-3LZ-01	10 – 40	7	250	65	80	707	Open Frame LGA 25 x 25 x 4.5
QPI-5LZ	10 – 40	14	250	60	75	707	LGA 25 x 25 x 4.5
QPI-5LZ-01	10 – 40	14	250	60	75	707	Open Frame LGA 25 x 25 x 4.5
QPI-6LZ	30 – 80	14	250	40	80	1,500	LGA 25 x 25 x 4.5
QPI-6LZ-01	30 – 80	14	250	40	80	1,500	Open Frame LGA 25 x 25 x 4.5
QPI-8LZ	36 – 76	6	250	40	70	1,500	LGA 25 x 25 x 4.5
QPI-8LZ-01	36 – 76	6	250	40	70	1,500	Open Frame LGA 25 x 25 x 4.5
QPI-11LZ	05 – 50	7	1,000	60	70	707	LGA 25 x 12.4 x 4.5
QPI-11LZ-01	05 – 50	7	1,000	60	70	707	Open Frame LGA 25 x 12.4 x 4.5
QPI-12LZ	05 – 80	7	1,000	40	70	1,500	LGA 25 x 12.4 x 4.5
QPI-12LZ-01	05 – 80	7	1,000	40	70	1,500	Open Frame LGA 25 x 12.4 x 4.5
QPI-21LZ	30 – 80	14	250	45	80	1,500	LGA 25 x 25 x 4.5
QPI-21LZ-01	30 – 80	14	250	45	80	1,500	Open Frame LGA 25 x 25 x 4.5

Typical Application

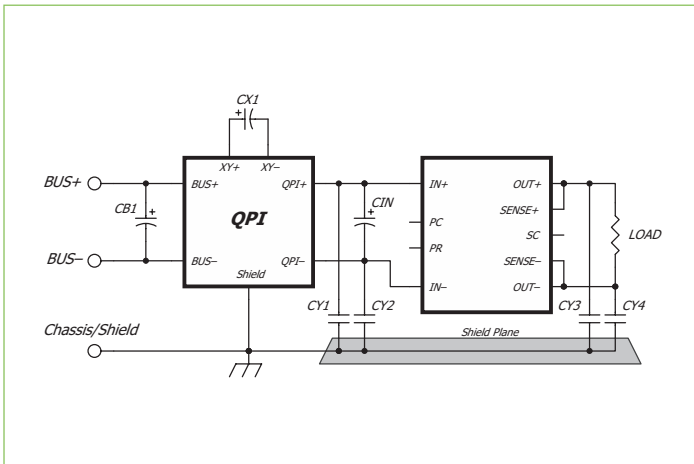

Figure 1 — Typical QPI-21 circuit with a Vicor brick converter.
Optional X (CX1) filter capacitor shown

Performance

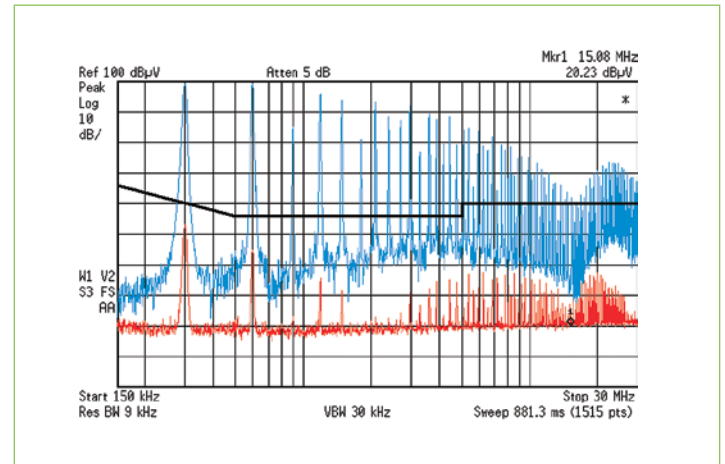

Figure 2 — Conducted EMI scans showing QPI performance.
Blue trace = no QPI; Red trace = with QPI