

PI358x-00-EVAL1

ZVS Regulators

30 – 60V_{IN} ZVS Buck Evaluation Board User Guide



Contents	Page
Introduction	1
Box Contents	3
Test Equipment	3
Features	3
Board Operation Modes	4
Thermal Consideration	4
Power Up Procedure	4
Board Description	5
General Components	6
Test Points Description	7
Schematic	8
Board Assembly	11
Bill of Materials	14

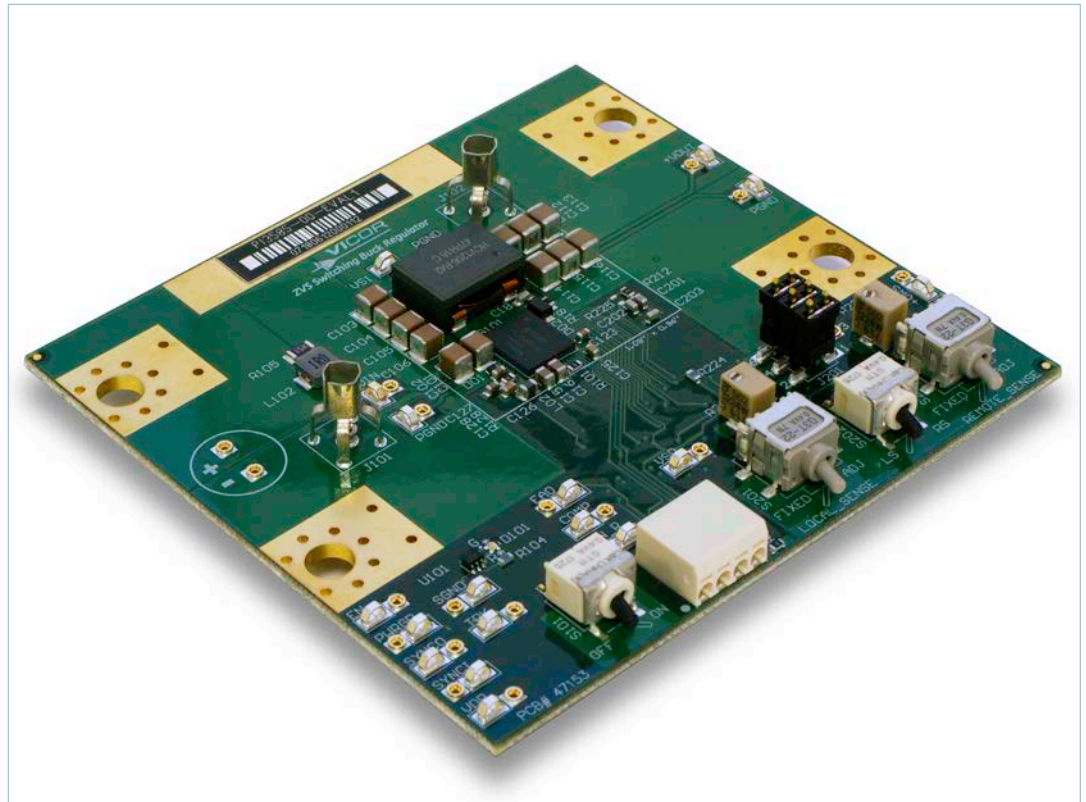

Note: Actual evaluation board appearance may vary slightly depending on product ordered

Introduction

This customer evaluation board is designed for the PI358x family of 7 x 8mm ZVS Bucks. It can be configured to demonstrate a single product in a standalone local-sense or a remote-sense configuration.

The PI358x family of wide input range DC-DC ZVS Buck regulators feature high efficiency with integrated controller and power switches within a high-density 0.28 x 0.32in GQFN package. Required external components are placed inside a demarcation featuring a solution size of 1.09 x 0.96in. The demarcation includes an external inductor, compensation capacitor, voltage selection resistors, soft-start capacitor and input-output capacitors to form a complete DC-DC regulator.



IMPORTANT NOTICE:

Be sure to read the precautions below entirely BEFORE using the Evaluation Board. Do not operate the evaluation board unless you have the appropriate safety precautions in place on your bench to ensure a successful experience.

The list below is not comprehensive and is not a substitute for common sense and good practice.

- Refer to the specific regulator module data sheet for electrical rating of the device, thermal and mechanical product details. It is important to remain within the device rated range when testing.
- When testing electronic products always use approved safety glasses. Follow good laboratory practice and procedures.
- During operation insure the power devices and surrounding structures can be operated safely.
- Care should be taken to protect the user from accidental contact when under power.
- Provide a strain relief for wires and place the system on the bench in such a way as to prevent accidental displacement from bench top.
- Review thermal consideration and guideline associated with operating the evaluation board. Most notably use a bench top fan and use rubber feet to elevate the PCB as they allow air flow to the bottom.
- Remove power and use caution when connecting and disconnecting test probes and interface lines to avoid inadvertent short circuits and contact with hot surfaces.
- Verify power connections to avoid reversing applied voltage polarities.
- Avoid creating ground loops between the SGND and PGND pins when making measurements.
- The product evaluation board is designed for general laboratory evaluation. It is not recommended for installation in end user equipment.

The evaluation board is designed to facilitate the evaluation of the performance of Vicor mounted ZVS buck products. Sockets are provided to permit quick probing. Input sockets can be used to place a bulk capacitor. The evaluation board provides lugs, and bottom layer banana jack footprint for input and output connections, signal connectors allowing wire, signal test points for easy connection to standard test equipment, and Kelvin Johnson-Jack for accurate voltage measurements of power nodes.

Box Contents

The evaluation board ships with the following contents:

- 1 Evaluation board
- 3 x pre-installed jumpers
- 1 x hardware kit: 5 x size 10 screws, lugs and washers

Recommended Test Equipment

The following is a list of recommended test equipment.

1. Safety glasses.
2. DC power supply: Refer to the specific PI358x model data sheet to ensure the supply has sufficient power and current capability.
3. Electronic load: Refer to the specific PI358x model data sheet to ensure the load has sufficient power handling and current capability for testing.
4. Bench top cooling fan.
5. Digital multi-meters (DMMs).
6. Oscilloscope and probes.
7. Interconnect wires, cables and fastening hardware.

Features

1. Input and output lugs for source and load connections.
2. Input sockets to place through-hole input aluminum-electrolytic capacitor.
3. Input source filter (L102, R105).
4. Toggle switch (S101) for enabling and disabling the regulator through the EN pin.
5. Oscilloscope probe jack for accurate, high-frequency input (J101) and output (J102) voltage measurement.
6. Signal pins test points and wire connectors.
7. Kelvin voltage test points and sockets for all pins of the GQFN product.
8. Access to voltage switching node VS1 with a nearby ground receptacle.
9. Mode selection switch for local (default) and remote sense loop.
10. Trim control selection for both local and remote sense:
 - a. ADJ: potentiometer to exercise the full output range. ^[a]
 - b. Fixed: resistor to set unit to nominal output.
11. Local- and remote-sense AC signal injection (J201).

^[a] Due to the tolerance of the trim potentiometer, trim range is $\pm 10\%$ of nominal V_{OUT} min and nominal V_{OUT} max.

Board Operation Modes

- S101 provides control to enable / disable the powertrain.
 - In the “OFF” position, the switch will connect SGND pin to the EN net, which disables the regulator output.
 - In the “ON” position, the EN net is allowed to float.
- The PI358x evaluation board supports the following operating modes:

Mode	S202	S201	S203	J201	(+VRS, -VRS)
Local loop, fixed Nominal output	LS	FIXED	–	Place jumper (J201 pin 1-2) to short R211 for accurate result	–
Local loop, with Trim range (R206)	LS	ADJ	–	Turn (R206) counterclockwise to increase the output voltage and clockwise to decrease the output voltage.	–
Remote loop, fixed Nominal output	RS	–	FIXED	Place jumper (J201 pin 1-2) to short R211 for accurate result	Used to connect to point of load. If not connected (R223-R224 = 100Ω) will be in the loop connecting this node to local +VOUT
Remote loop, with Trim range (R221)	RS	–	ADJ	Turn (R221) counterclockwise to increase the output voltage and clockwise to decrease the output voltage.	

Thermal Consideration

A fan blowing across the evaluation board is recommended but not required for operation. The fan should be placed about 4 inches away from the evaluation board edge. A typical bench top fan is recommended. Using the supplied rubber feet is suggested in order to elevate the board about 0.4 inches off a flat surface and enable air flow underneath the PCB.

Power Up Procedure

1. Confirm bench equipment is powered off.
2. Connect input DC power supply positive lead to +VIN input lug, then connect input power supply negative lead to PGND input lug of the evaluation board.
3. Connect +VOUT lug to the electronic load positive input, connect the PGND output lug to the electronic load negative input.
4. Verify proper polarity of both input and output connections.
5. Verify on-board mechanical switch (S101) desired actuator position. “ON” state allows power up upon application of input voltage. S101 default actuator position is “ON” allowing the unit to power up upon the application of an input voltage greater than V_{UVLO_START} .
6. Verify that three separate two position jumper socket are placed on header (J201) shorting the following J201 pins 1 to 2, 3 to 4, 5 to 6.
7. Verify desired feedback loop operation:
 - On-board mechanical switch (S202) default position is “LS” short for local sense loop
 - On-board mechanical switch (S201) default position is “FIXED” implying the use of the populated exact value resistors producing a regulated, device-specific, nominal output voltage.
8. Place measuring equipment such as DMM, scope probes as desired
9. Direct airflow from the cooling fan towards the evaluation board.
10. Download the latest product data sheet from Vicor power product page and have it on hand for reference
11. Apply input voltage greater than the minimum Input undervoltage lockout start threshold (V_{UVLO_START}). Ensure the input voltage slew rate is less than 1V/μs.

Board Description

The following section provides a detailed description of the evaluation board features.

Figure 1
PI358x evaluation board photo,
top side

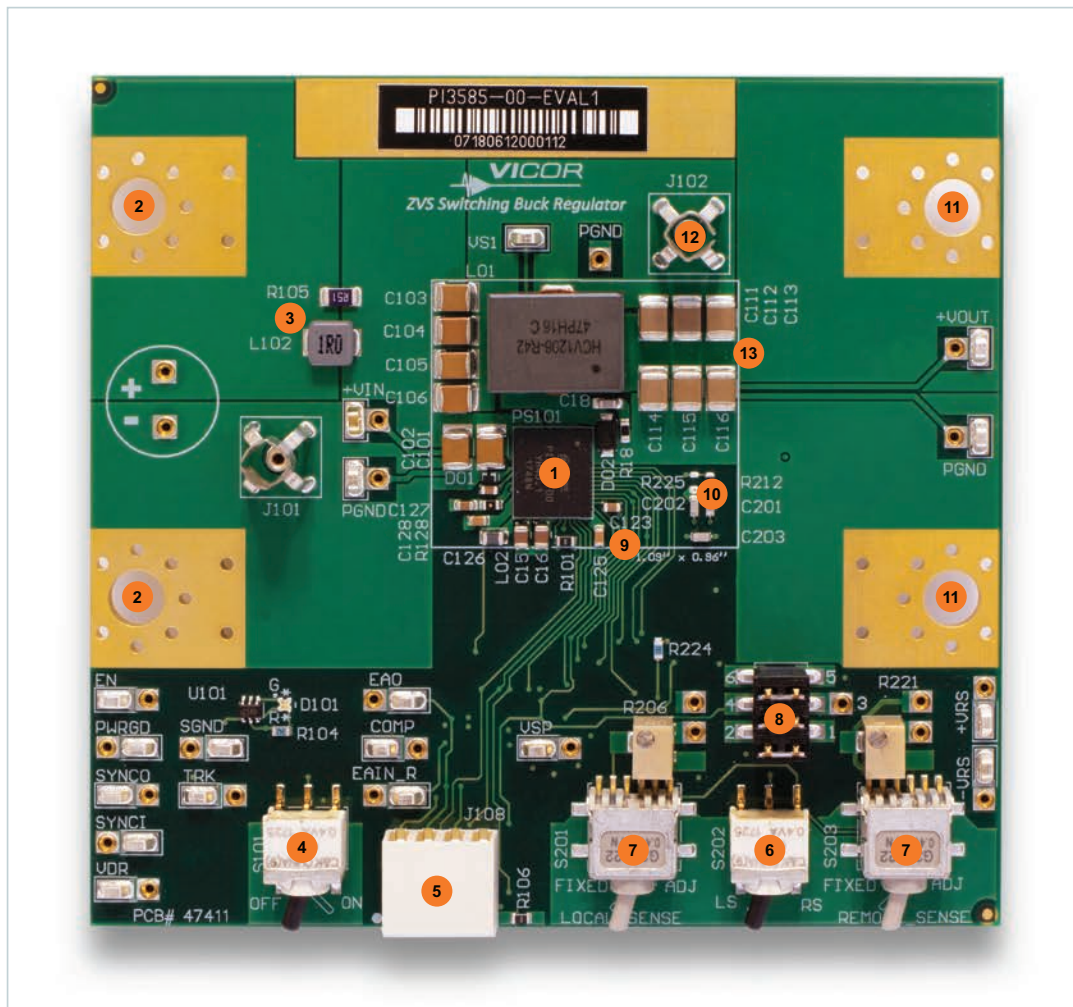
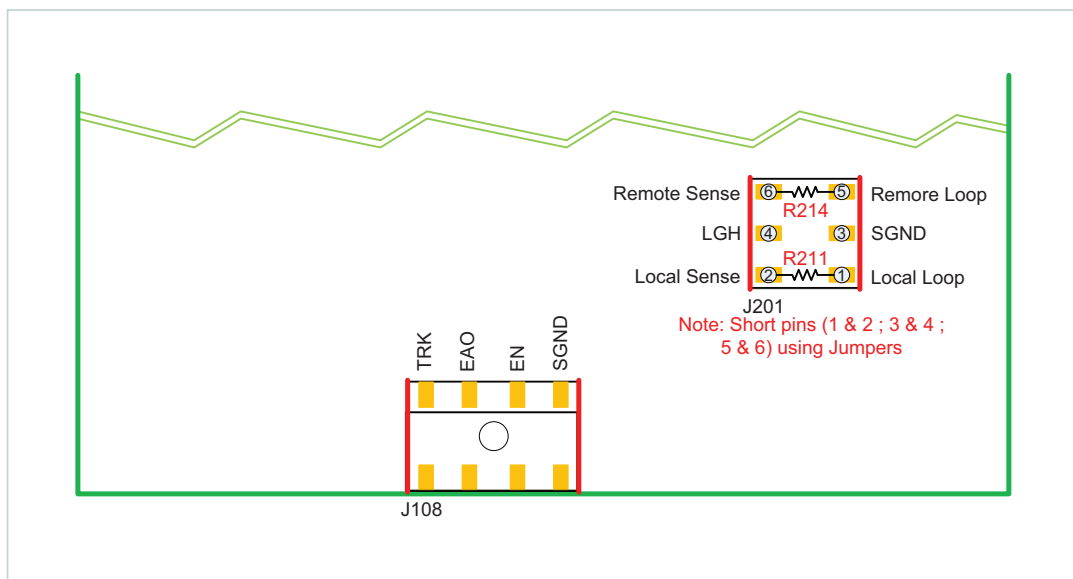

Figure 2
Signal connector and header
pinout, front view



General Components

1. PI358x family product (PS101).
2. Input lugs: Sized for #10 hardware. Use for making connection to the input source. This board does not contain reverse polarity protection. Check for proper polarity before applying power.
3. Input filtering: Sockets provision can be used for easy installation of aluminum-electrolytic input capacitor and filtering (inductor and ceramic capacitors) allows for stable operation with most input sources. 6 x 2.2 μ F output ceramic capacitors 1210 (C101 – C106) are used to achieve <2% of V_{IN} peak-to-peak ripple.
4. Enable / Disable switch (S101): When actuator is towards "ON" position, the (EN) pin will be open and the regulator will be allowed to power up. When actuator is towards "OFF", the EN pin will be connected to SGND pin and the regulator will be disabled. When switch (S101) is "ON," an external voltage source can control the EN pin state using the external EN test point.
5. Wire to board connector (J108): provides access to the regulator signal. All signal pins are reference to SGND.
 - TRK: An external capacitor may be connected between TRK pin and SGND to slow down the internal reference ramp. With this pin connected to an external capacitor the output voltage will track the slope effectively executing a soft-start function. See data sheet for additional tracking options.
 - EAO: Internal transconductance amplifier output pin.
 - EN: Regulator enable pin. Regulator is disabled when (S101) is in "OFF" state as this pin is connected to SGND. In "ON" state the module pin is allowed to float.
 - SGND: Internal logic ground return for all module. SGND to PGND connection is made inside the regulator package.
6. Loop compensation mode selection (S202): Used to select one of the following:
 - Local Sense (LS): default. Single ended feedback loop using the internal to the regulator operational transconductance amplifier. +VOUT Lug is the local sensed location. +VOUT lug is connected to the Error Amplifier Inverting Input (EAIN) through a voltage divider network.
 - Remote Sense (RS): Non-isolated remote sensing option using the internal to the regulator independent differential amplifier which outputs (VDIFF) is in turn connected to the transconductance amplifier input (EAIN) pin. Remote sensing is achieved using +VRS and -VRS test points. Resistors R223 and R224 are 100 Ω catch resistor placed to prevent an open loop condition if accidentally switched to this mode.
7. Trim mode selection (S201 or S203): Switch (S201) and trim potentiometer (R206) are associated with local sense loop while switch (S203) and trim potentiometer (R221) are associated with remote sense selection. Both Switches (S201 and S203) provide the following trim modes:
 - Fixed Trim (FIXED): default. Fixed resistor divider is used to set regulator output to the nominal data sheet output voltage.
 - Adjustable Trim (ADJ): selection allows the use of trim potentiometer (R206 or R221) to exercise the full output voltage range. Turn counterclockwise to increase the output voltage and clockwise to decrease the output voltage. The trim potentiometer at either lowest or highest point can only exercise the voltage range defined in the data sheet as valid operational range within tolerance limits. If preferred, through-hole receptacles are available to bypass the potentiometer with external leaded resistor.
8. Header-jumper (J201): Default setting is all three jumper sockets populated. This header provides the following function:
 - Pin 1 and pin 2 can be used to inject the isolated signal of a network analyzer through (R211= 49.9 Ω) used for bode plot measurement in order to evaluate the stability in local sense mode.
 - Pin 3 and pin 4 are used to short the Lighting (LGH)/Constant Current (CC) Sense Input to SGND. LGH header pin 4 is used for lighting and constant current type applications. When not in use the constant current mode (CC mode), the LGH pin should be connected to SGND. Refer to the product data sheet for availability of this pin function.
 - Pin 5 and pin 6 can be used to inject the isolated signal of a network analyzer through (R214 = 49.9 Ω) used for bode plot measurement in order to evaluate the stability in remote sense mode.

9. Soft-start capacitor (C123): Capacitor connected to regulator TRK pin and SGND. The soft-start time is set with an internal 47nF capacitor to roughly 0.94ms. C123 can be added to further stretch the soft-start ramp $C_{TRK} = (t_{TRK_DESIRED} \times 50E-6) - 47E-9$ where $I_{TRK} = 50\mu A$.
10. Internal operational transconductance amplifier compensation network (C201, R212, R225, C202): this network provides flexibility during loop compensation design to adjust the compensation. For the purpose of this evaluation board C201 in series to the internal R_{Z1} of 6k Ω is used. The maximum mid-band gain that can be achieved when using the internal R_{Z1} is roughly $(20 \bullet \log(R_{Z1} \bullet g_m \bullet V_{REF} / V_{OUT_SET}))$. With a reference voltage of 0.99V and output voltage of 5V max midband gain is ~14dB. R212 + R_{Z1} in series can be used to further increase the mid-band gain. C202 can be used to lower the high frequency pole if desired. The high-frequency pole is set internally to ~1.7MHz using a $C_{HF} = 56pF$.
11. Output lugs: Sized for #10 hardware. Use these lugs to connect the output directly to the load.
12. Output oscilloscope probe Jack (J102): Used for making accurate scope measurements of the output voltage (e.g. ripple). The jack is directly compatible with many common passive voltage probes models. Remove the grounding lead and insulating barrel of the probe and insert the probe tip and barrel directly into the jack, ensuring that the probe tip sits in the center socket of the jack. To avoid the risk of an inadvertent short circuit, do not attempt to install while power is applied. This Johnson Jack is kelvin connected to C112 positive pin.
13. Output filter: 6x ceramic capacitors 1210 (C111 – C116). Is used to achieve <1.5% of V_{OUT} peak to peak ripple.

Test Points Description

Each square point test point can be used with standard probes, clips or hooks. All test points are labeled on the board. Each test point is accompanied with an adjacent socket for adding a test lead or to facilitate wiring to external circuitry.

Table 1
Test point descriptions

Reference Designator/ Functional name	Description
+VIN, PGND	Input voltage test points provide connection to input lugs. Use Kelvin (J101) to avoid interconnection losses if accuracy is desired.
+VOUT, PGND	Output voltage test points provide connection to output lugs. Use Kelvin (J102) to avoid interconnection losses if accuracy is desired.
VDR	A 5.1V auxiliary supply with max loading of 2mA. If used this pin must have a series resistance such as R103 = 1k Ω with a decoupling cap of 0.1 μF such as C124.
PWRGD	Power good indicator. During a regulator fault this pin is pulled internally to signal ground.
EN	Input to the regulator. If left floating or driven high ($V_{EN_MAX} = 5.5V$) regulator will be enabled.
SGND	Internal logic ground.
TRK	Soft-start and track input. An external capacitor may be connected between TRK pin and SGND to increase the rise time of the internal reference during soft-start.
COMP	Compensation pin. An internal 5k Ω is in series between this pin and the EAO pin. A default C201 = 4.7nF is used.
EAO	Error Amp output. External connection for additional compensation and current sharing.
EAIN_R	Error Amp Inverting Input separated with R222 = 0 Ω .
VSP	Non-inverting input to an independent differential amplifier.
+VRS, -VRS	Non-isolated remote sense input. When selecting remote sense feedback connect to the regulation point at the load.
J201	Used to inject the isolated signal of a network analyzer into the feedback loop. Pin injection point is depend on loop selection.

Schematic

Figure 3
PI358x evaluation board
schematic page 1

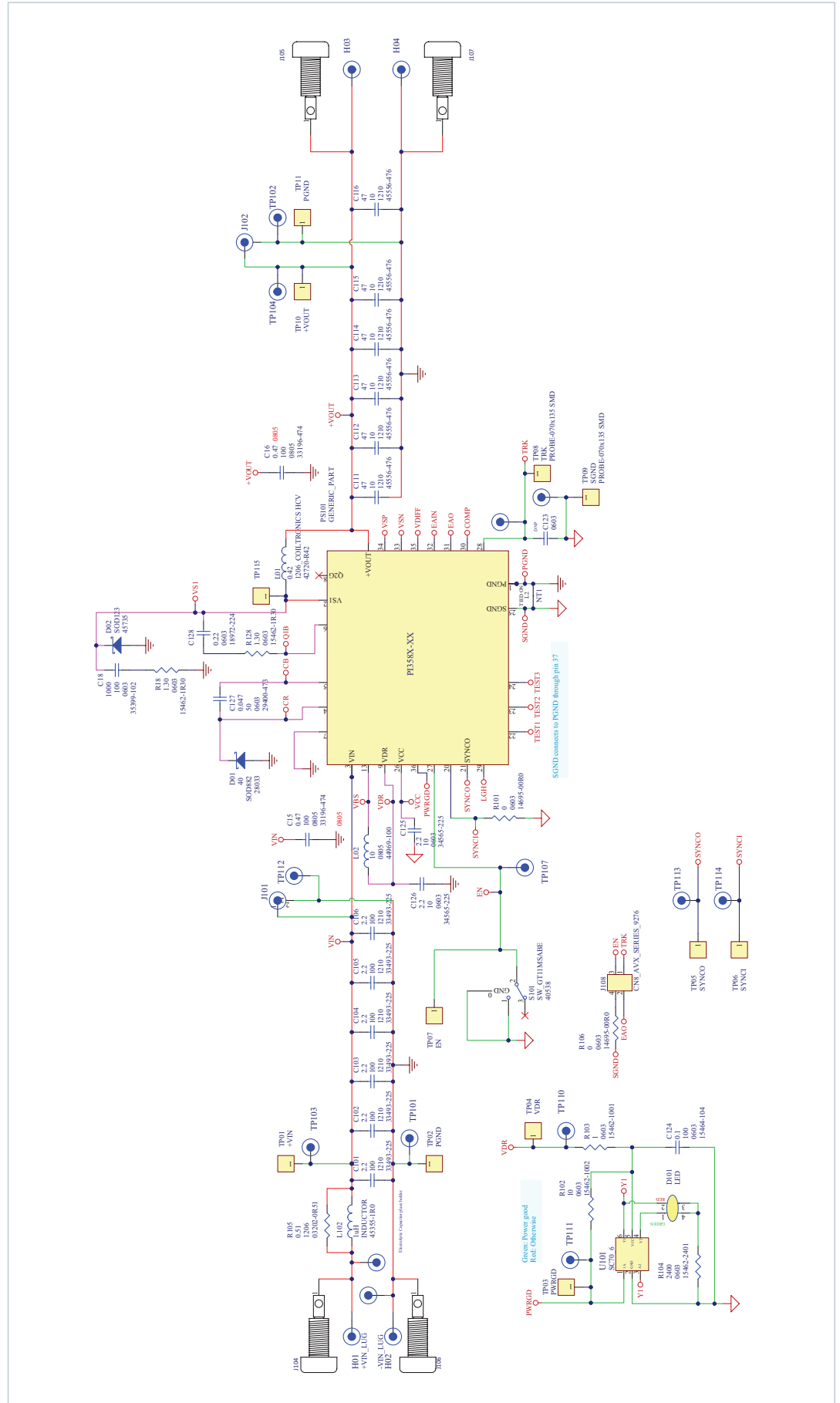

Schematic (Cont.)

Figure 5
PI358x evaluation board
schematic page 3

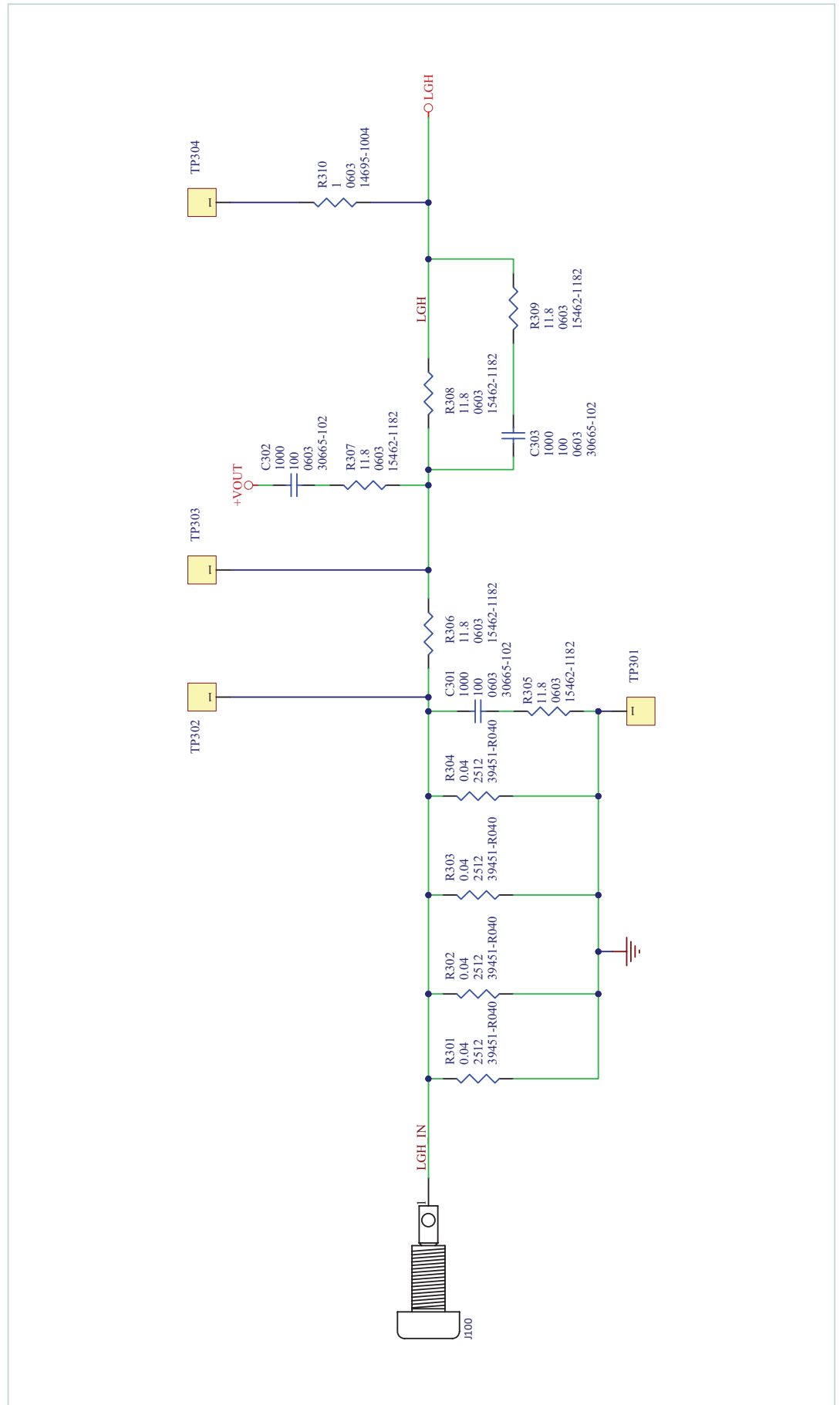

Board Assembly

Figure 6
PI358x evaluation board
assembly, top side

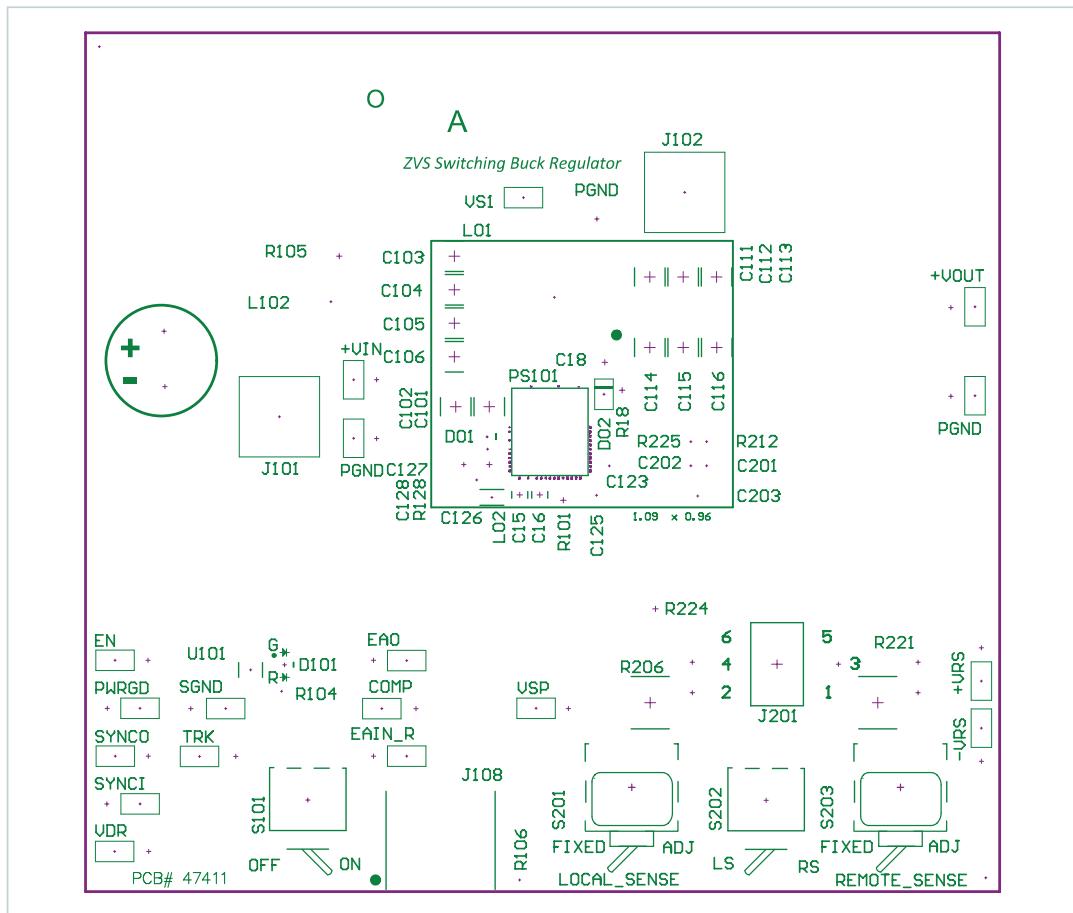
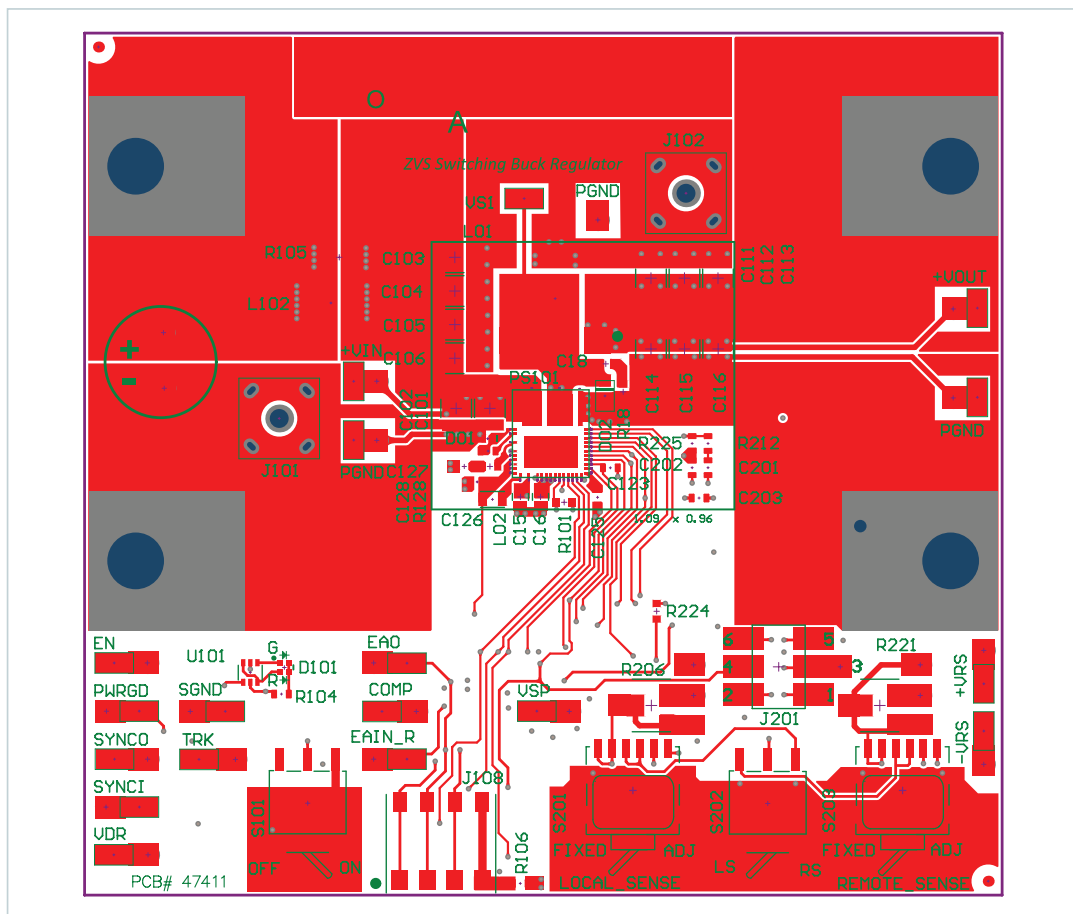

Figure 7
PI358x evaluation board
assembly, top layer



Board Assembly (Cont.)

Figure 8
PI358x evaluation board
assembly, mid layer 1

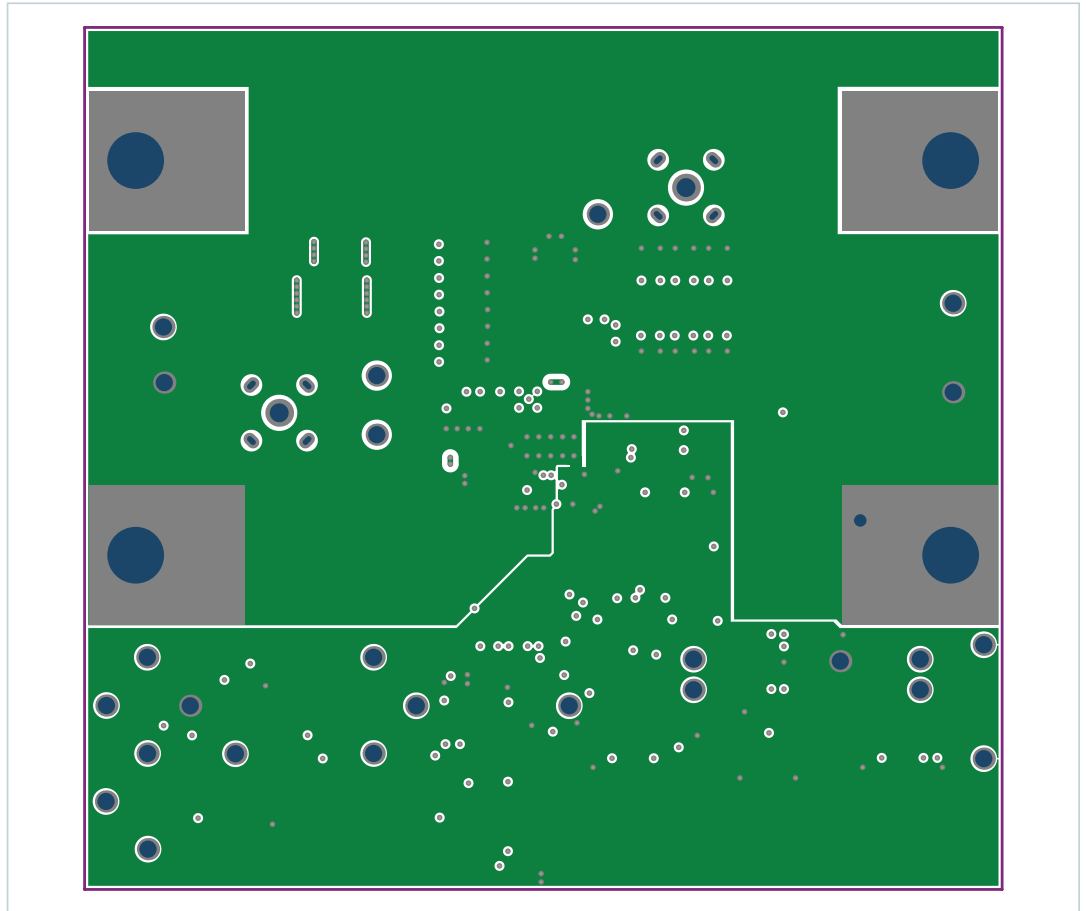
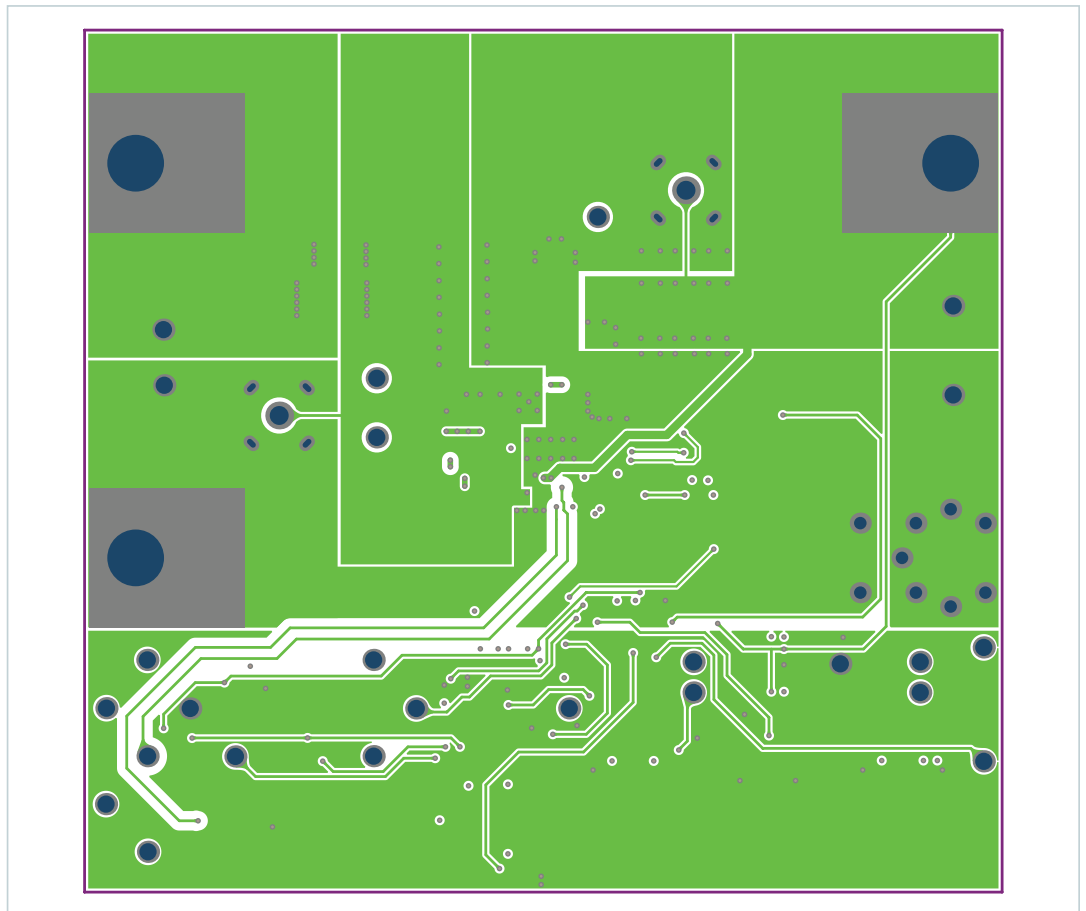
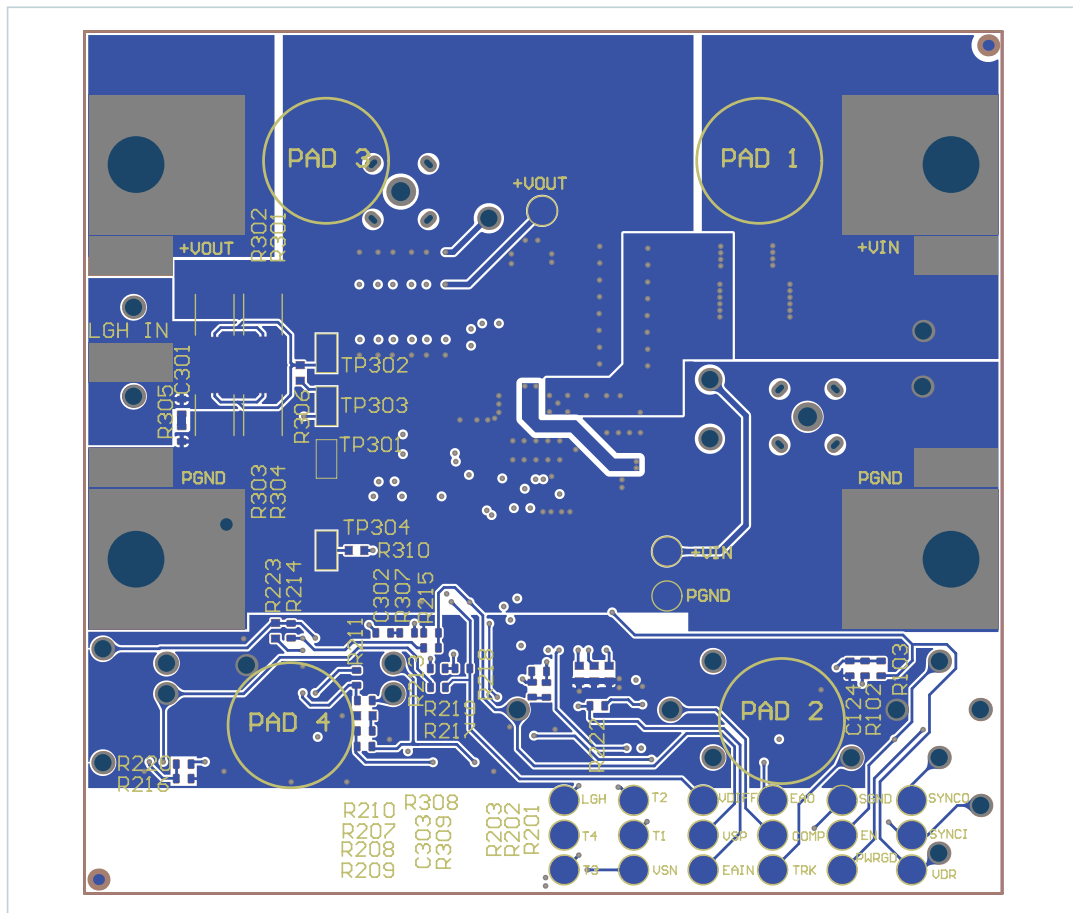

Figure 9
PI358x evaluation board
assembly, mid layer 2



Board Assembly (Cont.)

Figure 10
PI358x evaluation board
assembly, bottom layer



Bill of Materials

Table 2
PI358x common components

Reference Designator	Description	Qty	Manufacturer	Manufacturer Part Number
C101 – C106	CAP X7R 2.2μF 10% 100V 1210	6	Murata	GRM32ER72A225KA35L
C15, C16	CAP X7R 0.47μF 10% 100V 0805	2	Murata	GRM21BR72A474KA73K
C18	CAP NPO 1000pF 5% 100V 0603	1	Murata	GRM1885C2A102JA01J
C123	CAP X7R 0.047μF 10% 50V 0603	1	TDK	C1608X7R1H473K
C124	CAP X7R 0.1μF 10% 100V 0603	1	Murata	GRM188R72A104KA35J
C125, C126	CAP X7R 2.2μF 10%10V 0603	2	Murata	GRM188R71A225KE15D
C127	CAP X7R 0.10μF 10% 50V 0603	1	Murata	GRM188R71H104KA93D
C128	CAP X7R 0.22μF 10% 16V 0603	1	Murata	GRM188R71C224KA01D
C201	CAP X7R 4700pF 5% 100V 0603	1	TDK	C1608C0G2A-472J080AC
C202	CAP NPO 56pF 2% 100V 0603	1	AVX	06031A560GAT2A
CKIT	BOM CONN KIT ARRAY DEMO BD	1	Arnold Industries	26647
COMP, EAIN_R, EAO, EN, PWRGD, +VRS, -VRS, SGND, TRK, VDR, SYNCO, SYNCI, LGH, +VIN, PGND, +VOUT, PGND, VS1, VSP	TEST POINT, SURFACE MOUNT	19	Keystone Electronics	5017
D01	DIODE SCHOTTKY 40V 0.2A SOD882	1	Nexperia	PMEG4002EL,315
D02	DIODE SCHOTTKY 100V 1A SOD123W	1	NXP Semiconductors	PMEG10010ELR
D101	LED RED/GREEN 4 PIN 0404	1	Rohm	SML-P24MUWT86
J101, J102	JACK VERTICAL MECH THRU HOLE	2	Tektronix	131-5031-00
J108	CONN 4 POS WIRE TO BOARD SMD	1	AVX	009276004021106
J201	HEADER 6 PIN STRAIGHT SMT	1	FCI	95278-101A06LF
JMPR_1, JMPR_2, JMPR_3	JUMPER SOCKET 2POS 2.54mm WHANDLE	3	TE Connectivity	2-881545-2
L02	IND 10.0μH 20% 300mA 0805	1	TDK	MLZ2012M100HT000
L102	INDUCTOR 1μH 20% 5A 1716	1	Bourns	SRP4020TA-1R0M
PAD_1, PAD_2, PAD_3, PAD_4	ADHESIVE-BACK BUMPER, 3/8"D x 7/32"H	4	McMaster-Carr	95495K57
R18	RES 300mΩ 1/8W 1% 0603	1	Samsung	RUT1608FR300CS
R101, R106, R201, R202, R203, R212	RES 0Ω JUMPER 1A 0603	6	KOA Speer	RK73Z1JTDD
R102	RES 10kΩ 1/10W 1% 0603	1	KOA Speer	RK73H1JTDD1002F
R103, R309	RES 1kΩ 1/10W 1% 0603	2	KOA Speer	RK73H1JTDD1001F
R104	RES 2.4kΩ 1/10W 1% 0603	1	KOA Speer	RK73H1JTDD2401F
R105	RES 0.51Ω 1/4W 5% 1206	1	KOA Speer	SR732BTDDR51J
R128	RES SURGE 1.3Ω 1/4W 5% 0603	1	Rohm	ESR03EZPJ1R3
R206	RES TRIM POT 5kΩ 1/4W 10% SMD	1	Bourns	3224W-1-502E

Bill of Materials (Cont.)

Table 2 (Cont.)

PI358x common components

Reference Designator	Description	Qty	Manufacturer	Manufacturer Part Number
R211, R214	RES 49.9Ω 1/16W 0.1% 0603	2	Susumu	RG1608P-49R9-B-T5
R222	RES 2kΩ 1/10W 1% 0603	1	KOA Speer	RK73H1JTTD2001F
R223, R224	RES 100Ω 1/10W 1% 0603	2	KOA Speer	RK73H1JTTD1000F
R301, R302, R303	RES I SENSE 40mΩ 3W 1% 2512	3	Bourns	CRA2512-FZ-R040ELF
R308	RES 221kΩ 1/10W 1% 0603	1	KOA Speer	RK73H1JTTD2213F
S101, S202	SW Horizontal SPDT 1 POS SMD	2	C&K	GT11MSABETR
S201, S203	SW TOGGLE DPDT G3T22AH SMD	2	NKK	G3T22AH
TP101, TP102, TP103, TP104, TP105, TP106, TP107, TP108, TP109, TP110, TP111, TP112, TP113, TP114, TP115, TP201, TP203, TP207, TP208, TP209, TP210, TP211, TP212, TP215, TP216, TP217	PIN RECPT .015/.025 DIA 0667 SER TH	26	Mill-Max	0667-0-57-15-30-27-1
U101	IC SCHMITT TRIGGER INVERTER DUAL SC70-6	1	Fairchild	NC7WZ14EP6X
C301, C302, C303, J100, J104, J105, J106, J107, R225, R304, R305, R306, R307, R310	NOT APPLIED	14		

Table 3

PI358x design-specific components

Reference Designator	Description	Qty	Manufacturer	Manufacturer Part Number
Evaluation board number: PI3583-00-EVAL1				
PCB	SNGLTD PCB PI3583-00-EVAL1	1	Vicor Power Component	47411
PS101	NI BUCK REG 60V/3.3V 22A	1	Vicor Power Component	PI3583-00-QFYZ
L01	IND 420nH 10% 16A 22.2x8.2mm	1	Eaton	HCV1206-R42-R
C111 – C116	CAP X6S 100μF 20% 6.3V 1210	6	Murata	GRM32EC80J107ME20L
R207	RES 4.99Ω 1/16W 0.1% 0603	1	TE	CPF0603B4R99E1
R208	RES 1.02kΩ 1/10W 1% 0603	1	Panasonic	ERJ-3EKF1021V
R209	RES 1.37kΩ 1/10W 1% 0603	1	KOA Speer	RK73H1JTTD1371F
R210	RES 2.4kΩ 1/10W 1% 0603	1	KOA Speer	RK73H1JTTD2401F
R213, R215, R218, R219	RES 18.7kΩ 1/10W 1% 0603	4	KOA Speer	RK73H1JTTD1872F
R216	RES 1.2kΩ 1/16W 0.1% 0603	1	Susumu	RG1608P-122-B-T5
R217	RES 2.8kΩ 1/10W 1% 0603	1	KOA Speer	RK73H1JTTD2801F
R220	RES 1.24kΩ 1/10W 1% 0603	1	KOA Speer	RK73H1JTTD1241F
R221	RES TRIP POT 5kΩ 1/4W 10% SMD	1	Bourns	3224W-1-502E

Bill of Materials (Cont.)

Table 3 (Cont.)

PI358x
design-specific components

Reference Designator	Description	Qty	Manufacturer	Manufacturer Part Number
Evaluation board number: PI3585-00-EVAL1				
PCB	SNGLTD PCB PI3585-00-EVAL1	1	Vicor Power Component	47411
PS101	NI BUCK REG 60V/5V 20A	1	Vicor Power Component	PI3585-00-QFYZ
L01	IND 420nH 10% 16A	1	Eaton	HCV1206-R42-R
C111 – C116	CAP X7R 47µF 10% 10V 1210	6	Murata	GRM32ER71A476KE15L
R207	RES 4.99Ω 1/16W 0.1% 0603	1	TE	CPF0603B4R99E1
R208	RES 1.18kΩ 1/10W 0.1% 0603	1	Panasonic	ERA3AEB1181V
R209	RES 449Ω 1/10W 0.1% 0603	1	KOA Speer	RN731JTTD4990B25
R210	RES 4.81kΩ 1/10W 0.1% 0603	1	Vishay	TNPW06034K81BEEA
R213, R219	RES 10.2kΩ 1/10W 0.1% 0603	2	Vishay	TNPW060310K2BEEA
R215, R218	RES 2.74kΩ 1/16W 0.1% 0603	2	Susumu	RG1608P-2741-B-T5
R216	RES 1.27kΩ 1/10W 0.1% 0603	1	Vishay	TNPW06031K27BEEA
R217	RES 453Ω 1/10W 0.1% 0603	1	Susumu	RG1608P-4530-B-T5
R220	RES 4.64kΩ 1/16W 0.1% 0603	1	Susumu	RG1608P-4641-B-T5
R221	RES TRIM POT 5kΩ 1/4W 10% SMD	1	Bourns	3224W-1-502E

Table 3 (Cont.)

PI358x
design-specific components

Reference Designator	Description	Qty	Manufacturer	Manufacturer Part Number
Evaluation board number: PI3586-00-EVAL1				
PCB	SNGLTD PCB PI3586-00-EVAL1	1	Vicor Power Component	47411
PS101	NI BUCK REG 60V/12V 18A	1	Vicor Power Component	PI3586-00-QFYZ
L01	IND 900nH 10% 14A	1	Eaton	HCV1206-R90-R
LGH	TEST POINT, SURFACE MOUNT	1	Keystone Electronics	5017
C111 – C116	CAP X7R 10µF 10% 25V 1210	6	Murata	GRM32ER71H106KA12L
R207	RES 4.99Ω 1/16W 0.1% 0603	1	TE	CPF0603B4R99E1
R208	RES 316Ω 1/10W 0.1% 0603	1	Panasonic	ERA-3AEB3160V
R209	RES 324Ω 1/10W 0.1% 0603	1	Panasonic	ERA-3AEB3240V
R210	RES 3.57kΩ 1/10W 0.1% 0603	1	Panasonic	ERA-3AEB3571V
R213, R219	RES 20kΩ 1/16W 0.1% 0603	2	Susumu	RG1608P-203-B-T5
R215, R218	RES 6.12kΩ 1/16W 0.1% 0603	2	Vishay	PAT0603E6121BST1
R216	RES 1.47kΩ 1/10W 1% 0603	1	Panasonic	ERA3AEB1471V
R217	RES 4.02kΩ 1/10W 0.1% 0603	1	Panasonic	ERA-3AEB4021V
R220	RES 2.49kΩ 1/16W 0.1% 0603	1	Susumu	RG1608P-2491-B-T5
R221	RES TRIP POT 10kΩ 1/4W 10% SMD	1	Bourns	3224W-1-103E

Limitation of Warranties

Information in this document is believed to be accurate and reliable. HOWEVER, THIS INFORMATION IS PROVIDED "AS IS" AND WITHOUT ANY WARRANTIES, EXPRESSED OR IMPLIED, AS TO THE ACCURACY OR COMPLETENESS OF SUCH INFORMATION. VICOR SHALL HAVE NO LIABILITY FOR THE CONSEQUENCES OF USE OF SUCH INFORMATION. IN NO EVENT SHALL VICOR BE LIABLE FOR ANY INDIRECT, INCIDENTAL, PUNITIVE, SPECIAL OR CONSEQUENTIAL DAMAGES (INCLUDING, WITHOUT LIMITATION, LOST PROFITS OR SAVINGS, BUSINESS INTERRUPTION, COSTS RELATED TO THE REMOVAL OR REPLACEMENT OF ANY PRODUCTS OR REWORK CHARGES).

Vicor reserves the right to make changes to information published in this document, at any time and without notice. You should verify that this document and information is current. This document supersedes and replaces all prior versions of this publication.

All guidance and content herein are for illustrative purposes only. Vicor makes no representation or warranty that the products and/or services described herein will be suitable for the specified use without further testing or modification. You are responsible for the design and operation of your applications and products using Vicor products, and Vicor accepts no liability for any assistance with applications or customer product design. It is your sole responsibility to determine whether the Vicor product is suitable and fit for your applications and products, and to implement adequate design, testing and operating safeguards for your planned application(s) and use(s).

VICOR PRODUCTS ARE NOT DESIGNED, AUTHORIZED OR WARRANTED FOR USE IN LIFE SUPPORT, LIFE-CRITICAL OR SAFETY-CRITICAL SYSTEMS OR EQUIPMENT. VICOR PRODUCTS ARE NOT CERTIFIED TO MEET ISO 13485 FOR USE IN MEDICAL EQUIPMENT NOR ISO/TS16949 FOR USE IN AUTOMOTIVE APPLICATIONS OR OTHER SIMILAR MEDICAL AND AUTOMOTIVE STANDARDS. VICOR DISCLAIMS ANY AND ALL LIABILITY FOR INCLUSION AND/OR USE OF VICOR PRODUCTS IN SUCH EQUIPMENT OR APPLICATIONS AND THEREFORE SUCH INCLUSION AND/OR USE IS AT YOUR OWN RISK.

Terms of Sale

The purchase and sale of Vicor products is subject to the Vicor Corporation Terms and Conditions of Sale which are available at: (<http://www.vicorpower.com/termsconditionswarranty>)

Export Control

This document as well as the item(s) described herein may be subject to export control regulations. Export may require a prior authorization from U.S. export authorities.

Contact Us: <http://www.vicorpower.com/contact-us>

Vicor Corporation
25 Frontage Road
Andover, MA, USA 01810
Tel: 800-735-6200
Fax: 978-475-6715
www.vicorpower.com

email

Customer Service: custserv@vicorpower.com
Technical Support: apps@vicorpower.com