

THIS DOCUMENT AND THE DATA DISCLOSED HEREIN OR HEREWITH IS NOT TO BE REPRODUCED, USED, OR DISCLOSED IN WHOLE OR IN PART TO ANYONE WITHOUT PERMISSION OF VICOR CORP.

REV.	DESCRIPTION	DATE	APPROVED
1	RELEASED PER E060449	01/25/06	SH
2	RELEASED PER E060875	7/17/06	MB

WITHOUT BOTTOM SPACER

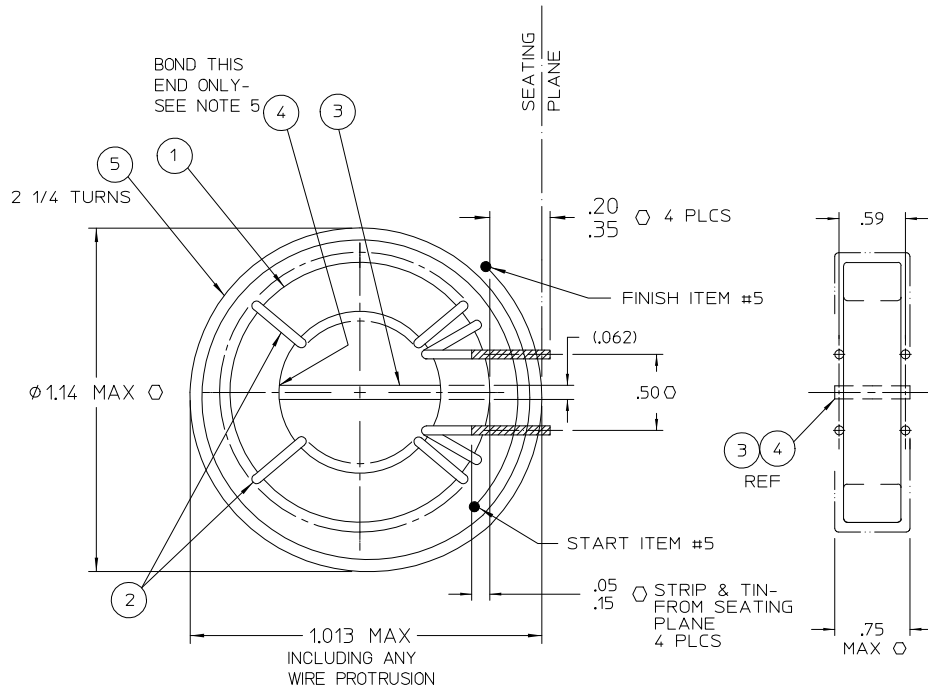

WITH BOTTOM SPACER

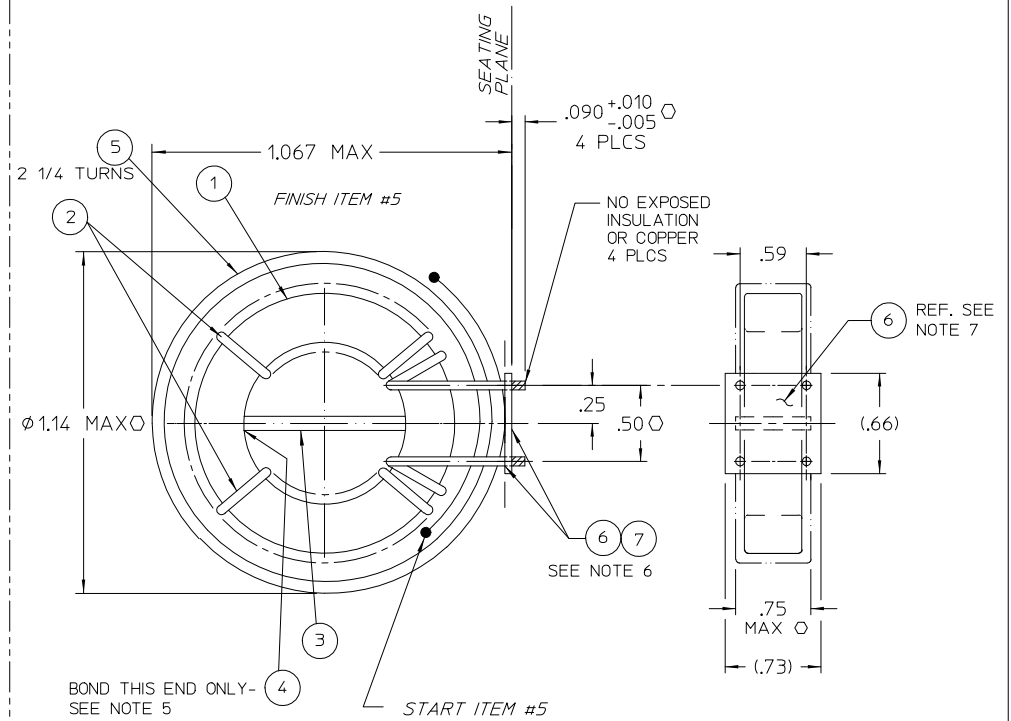

NOTES:

1. ASSEMBLY TO BE FREE OF NICKS.
2. WINDINGS TO BE EVENLY SPACED.
3. RoHS COMPLIANT, LEAD FREE PER CST-0001 LATEST REVISION, MAGNETICS SECTION.
4. GENERAL WORKMANSHIP STANDARDS FOR MAGNETIC COMPONENTS PER WS-0002.
5. BOND SPACER (ITEM 3) TO CORE (ITEM 1) USING ADHESIVE (ITEM 4) ONE END ONLY.
6. BOND SPACER (ITEM 6) TO DEVICE LEADS (4 PLACES), USING ADHESIVE (ITEM 7).
7. ORIENTATION OF ITEM 6 TO BE AS SHOWN.
8. ASSEMBLY MAY NOT HAVE ITEM 5 (TAPE).
9. O DENOTES CRITICAL CHARACTERISTIC FOR LOT INSPECTION.

DRAWN BY <i>P.E.IENI</i>	DATE 11/10/05			
<small>UNLESS OTHERWISE SPECIFIED DIMENSIONS ARE IN INCHES- TOLERANCES ARE:</small> <small>FRACTIONS DECIMALS ANGLES</small> <small>+1/64 .XX+ .01 °1°</small> <small>.XXX-.005</small>				
THIRD ANGLE PROJECTION 	SIZE C	FSCM NO. 67131	DWG NO. 32010	REV 2
DO NOT SCALE DRAWING	SCALE 2:1	SHEET 1 OF 1		

IND TOR 1.09 DIA 2W ASSY DWG