

High-voltage DC distribution is key to increased system efficiency and renewable energy opportunities



A transition to 400V_{DC} in power distribution and conversion will help meet greenhouse gas, efficiency and renewable-energy goals.

The pressure throughout the energy supply chain to deliver electrical power more efficiently is intense and growing. Most dramatically, the European Union's response to the Copenhagen Accord puts forth a "20-20-20" Energy Strategy, with goals of a 20% reduction in energy consumption, a 20% reduction in greenhouse gases and 20% reliance on power from renewable resources by 2020. These ambitious objectives are in place despite the enormous growth in major power consumers such as data centers ("server farms") as voice, data and networks converge and merge, while user demands increase in the range of 5 – 10% annually.

Existing solutions within the AC-DC conversion system topology are struggling to provide even a few percentage points of large-scale improvement despite localized improvements in performance. The answer may be to look instead to a very different AC-DC structure, based on new approaches rather than merely incremental ones. Using high-voltage DC for power transmission, in conjunction with new conversion approaches, offers tangible and significant benefits for both sourcing options and system end-to-end performance. In fact, some work from France Telecom and China Mobile estimate that between 8 and 10% across the board can be saved by going to DC distribution.

Ironically, this approach circles back to the 19th century and the earliest days of electric-power generation and distribution. Edison favored DC generation and distribution while Tesla advocated AC, with its availability of transformers for voltage step up and step down to reduce transmission (I^2R) losses. (Transformers were the only practical way to achieve needed voltage conversion despite their efficiency of just 50 – 80%; cumbersome motor/generator combinations were a far-inferior alternative). The battle was big and the stakes were high, with technical, economic and political consequences.

As we all know, AC won that battle. But new technical developments in components and devices, along with additional power-system objectives, are acting as catalysts to make DC-based systems a better and available alternative. These developments include innovative conversion, control and distribution approaches, much of which is enabled by advanced semiconductors and conversion topologies which function effectively in ways not previously possible. As a result, high-voltage DC (HVDC) systems are now practical for distribution and use within a building, office park, warehouse, school and factory.

Why use DC at all?

Why consider high-voltage DC (380V nominal/400V peak) instead of traditional AC, which is well established and field proven for over 100 years? There are several aspects to the answer. DC does not require source synchronization as AC does, and can draw upon wind, solar and the grid as each source is available. There are no phase-balancing or harmonic issues and no "stranded" equipment issues, all costly investments in infrastructure which may become obsolete or redundant.

DC offers a lower total cost of ownership (TCO) in building wiring, copper and connectors, along with an increase in efficiency of between 8 and 10%—truly significant. A properly configured DC system offers higher efficiency and more potential for power extraction from multiple available sources.

There are also benefits which are not as immediately apparent. Most backup energy sources, such as batteries and flywheels, are inherently DC. Further, telecom and server loads run on DC, so there are fewer intermediate, efficiency-robbing stages, along with greater reliability due to fewer potential points of failure with a DC-based approach.

The HVDC approach is not just a speculative dream or laboratory curiosity. It has industry-wide support from critical-component vendors, of course. It is also supported by industry consortia which are developing essential standards and interoperability specifications, such as the DCG+C [DC Components and Grid] consortium, the ITU [International Telecommunications Union] via standard L.1200, ETSI [European Telecommunications Standards Institute] via EN 300 132-3-1, the IEC [International Electrotechnical Commission], NTT/Japan [Nippon Telegraph and Telephone] and the IEEE.

Topology makes a difference

Before looking at the topology and implementation of a 400V_{DC} distribution approach, first look at the existing approaches used for major power consumers such as data centers or telecom central offices. In the data center, Figure 1, an incoming high-voltage AC line is stepped down and then converted to DC so it can be paralleled with a battery-backup system. The DC is then converted back to high-voltage AC for distribution within the building, then converted yet again from AC down to lower-voltage DC and then to voltages for the circuitry rails via DC-DC converters. Thus, there are four major conversion stages from incoming AC to final DC.

Figure 1
A typical data center has four major conversion stages from incoming AC line to final DC rails

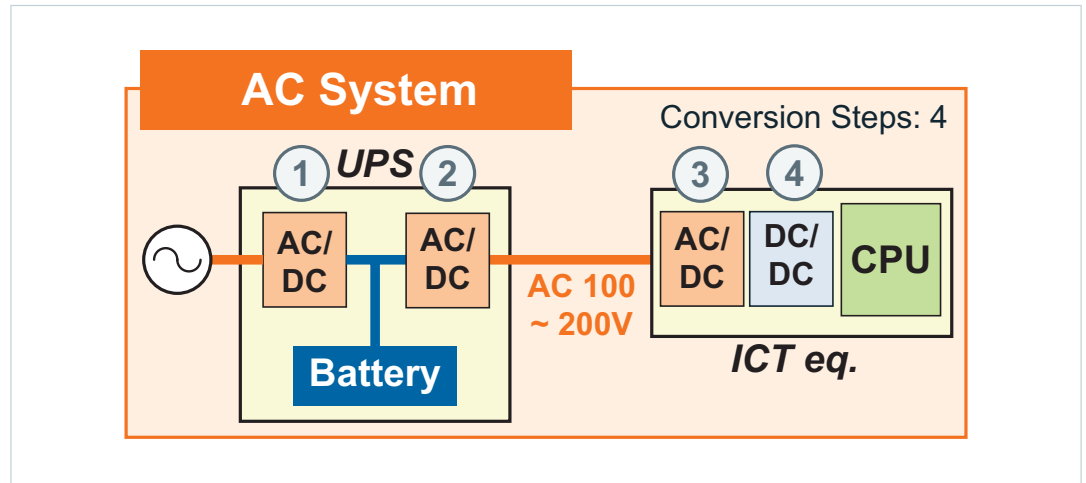

For the existing telecom system, there are just two major stages but with major points of inefficiency, Figure 2. The line AC is converted to 48V_{DC} and combined with the backup batteries; this 48V_{DC} line then supplies an array of DC-DC converters which provide the local, low-voltage rails needed for the circuitry.

The HVDC system also has just two major conversion stages, but there is more to the end-to-end performance metric than the number of stages alone, as the efficiency of each stage is also critical. In the HVDC approach, the stages are both more efficient and more reliable.

Figure 2
For existing telecom systems, the two major stages of current telecom systems are major points of inefficiency

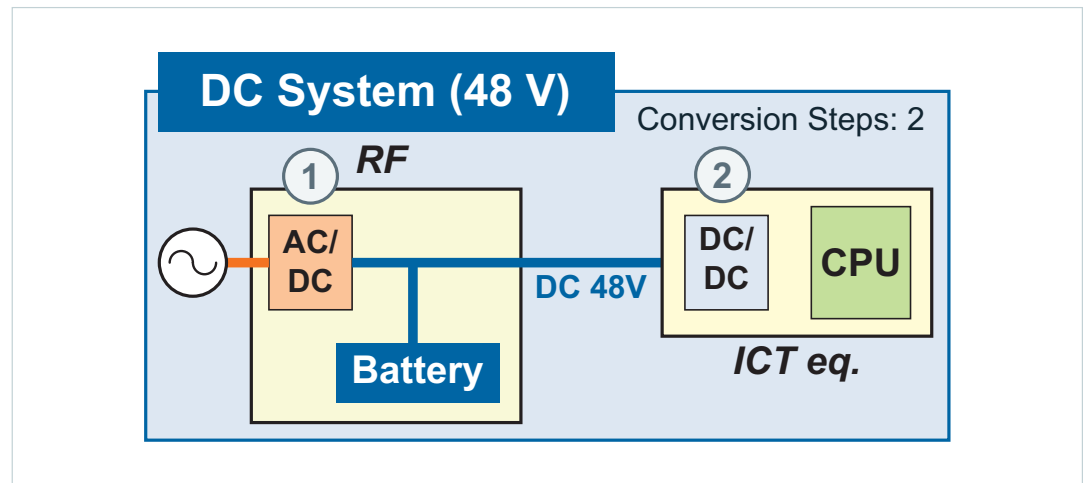

The HVDC topology begins with the line AC rectified to $380V_{DC}$ (nominal), with the battery backup also operating at that voltage, Figure 3. The DC voltage is then distributed throughout the facility and stepped down by local DC-DC converters to supply the rails of the processor and various loads. The system can draw on the outside AC line, batteries and even onsite renewable sources such as wind and solar simultaneously or individually, in case there is a failure (such as grid problems due to a storm).

Figure 3

The line AC is rectified to $380V_{DC}$ (nominal), while the battery backup also operates at that voltage in the HVDC topology

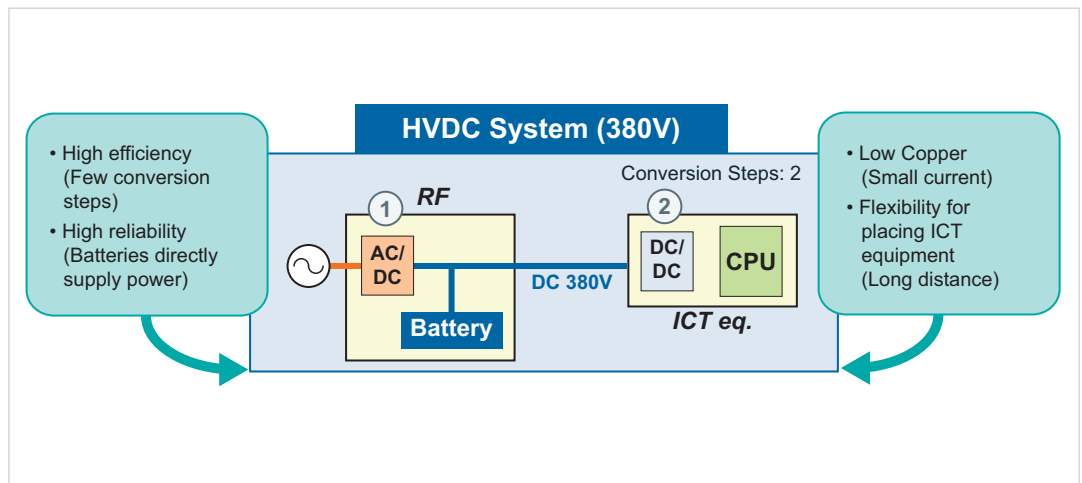

Getting down to single volts

The reality is that most circuitry operates from DC voltages below 12V, and even down to the 1V region. The challenge for any distribution/conversion system is to develop and deliver those low voltages (and their high currents) efficiently and reliably.

HVDC can meet this requirement, as well, using several available building blocks. One is a Sine Amplitude Converter™ (SAC™), used in the form of a BCM® Bus Converter, which is an isolated, non-regulated DC-DC converter which uses a zero-voltage/zero-current switching architecture, Figure 4. The SAC is like a traditional AC transformer except that it is DC input/output, and has an input/output voltage ratio which is fixed by design. For example, with a transformer ratio (K) of 1/8, it produces a $50V_{DC}$ output from a $400V_{DC}$ input, and $47.5V$ from a $380V$ input.

Figure 4

To support the HVDC topology, designers can use a Sine Amplitude Converter (SAC) or BCM Bus Converter (an isolated, non-regulated DC-DC converter)

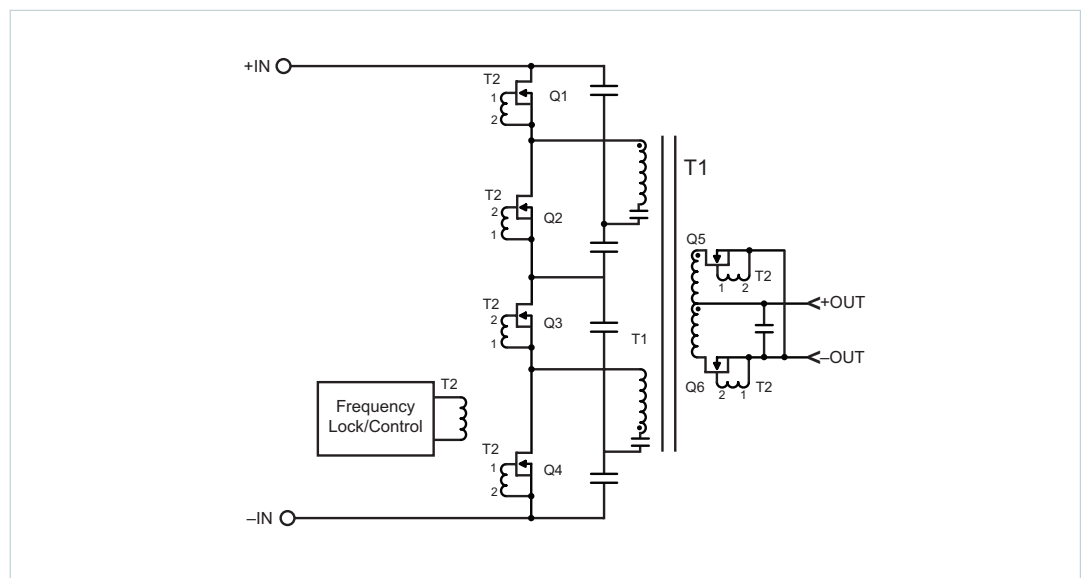

The SAC™ reaches over 96% efficiency partially due to its fixed, high-frequency (>1MHz), soft-switching topology. The result is a power density of 70W/cm³; a Vicor full-chip bus converter measuring just 3.25 × 2.2 × 0.67cm (1.28 × 0.87 × 2.265in.)—comparable to a standard RJ-45 Ethernet plug, Figure 5—can deliver up to 330W. The second block is the non-isolated buck-boost regulator, also using zero-voltage-switching and 1MHz operation, Figure 6, resulting in small size and high efficiency of 97%.

Figure 5

This Vicor bus converter is the size of a standard RJ-45 Ethernet plug, yet delivers up to 330W



Figure 6

Using zero-voltage switching at 1MHz operation, the non-isolated buck-boost regulator offers small size and 97% efficiency

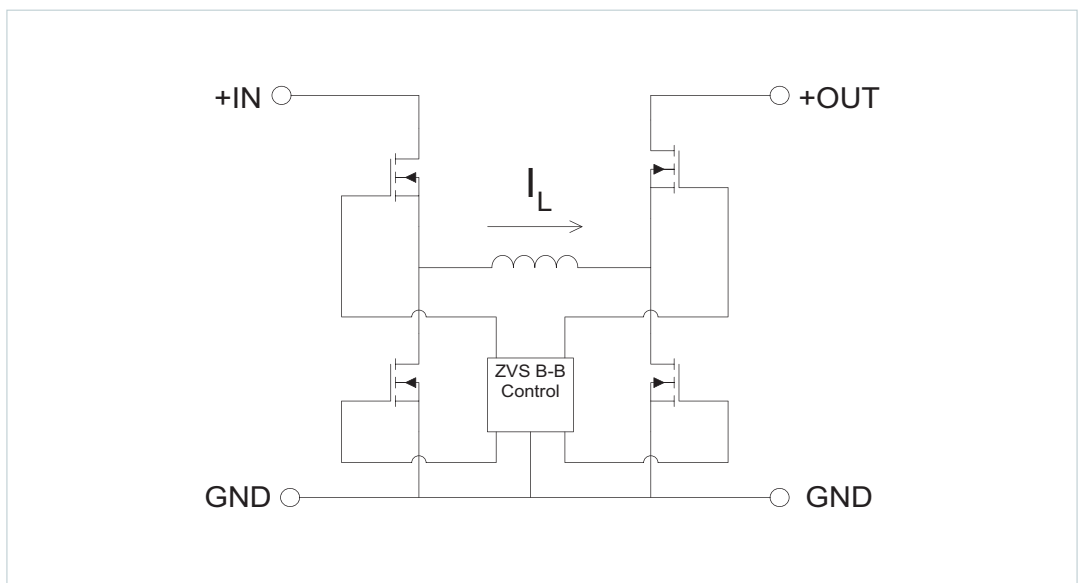

Working together, the SAC/BCM and buck-boost regulator provide an equalizer (adapter) function over the full span of input voltages for the normal service range as defined by ETSI, Figure 7. At the normal 380V point, the bus converter can drop the line down to 48V, with the equalizer operating in a power-through mode (with a bypassed buck-boost). Thus, system efficiency is enhanced because the unit converts only when needed. If the DC voltage from the line or battery drops towards 260V, the buck-boost converter "kicks in" and maintains the fixed 48V rail.

In either case, the architecture maintains high efficiency and allows for seamless, dynamic use of multiple sources—a rectified DC line, battery and renewables—as they become available.

Figure 7
Meeting the normal service range, as defined by ETSI, requires understanding of corner-case design considerations and uses multiple functional blocks

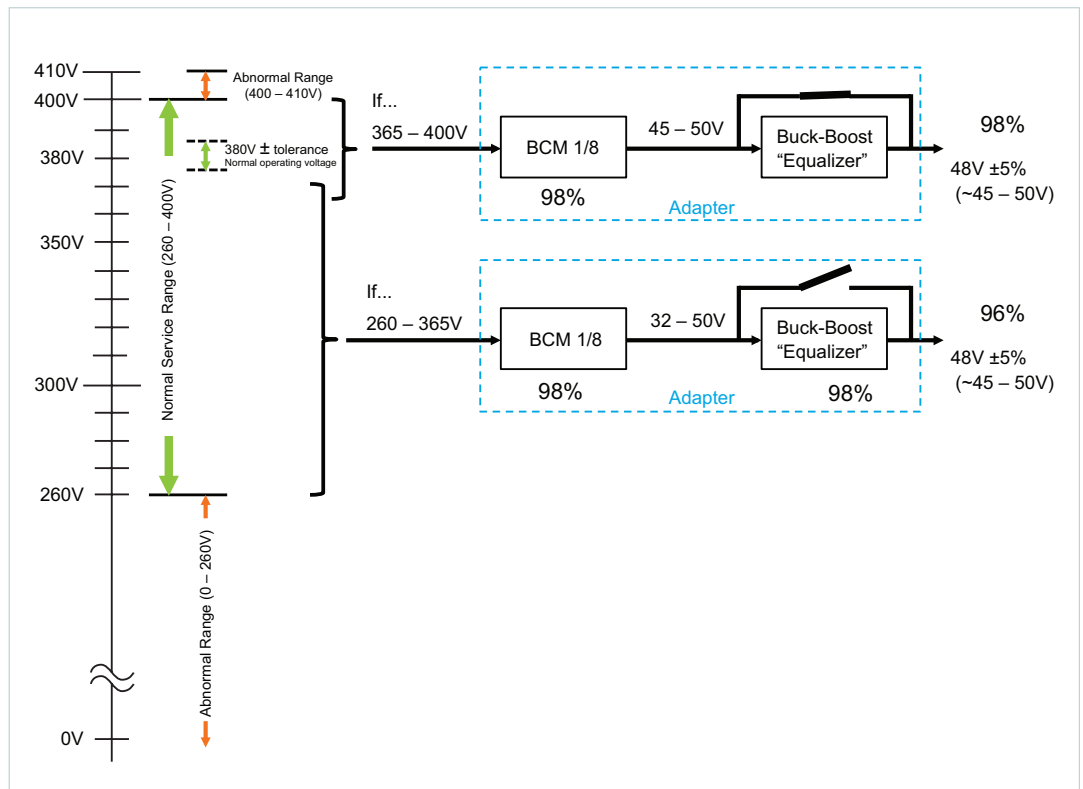

Legacy equipment is fully supported as well, starting with today's architecture of AC-to-48V_{DC} rectification, followed by a 48V_{DC} power-distribution unit (PDU) and then DC-DC and DC-AC modules for the lower voltages as needed, Figure 8. In the transition phase, Figure 9, the rectification would be at line voltage producing 380V_{DC}, followed by a HV PDU, and then a mix of 380V_{DC}, 48V_{DC} and lower-voltage AC (if needed) outputs, along with 48V/12V_{DC} (or 9.6V) bus converters for the final rails.

Figure 8
The use of multiple modules ensures that legacy equipment is supported

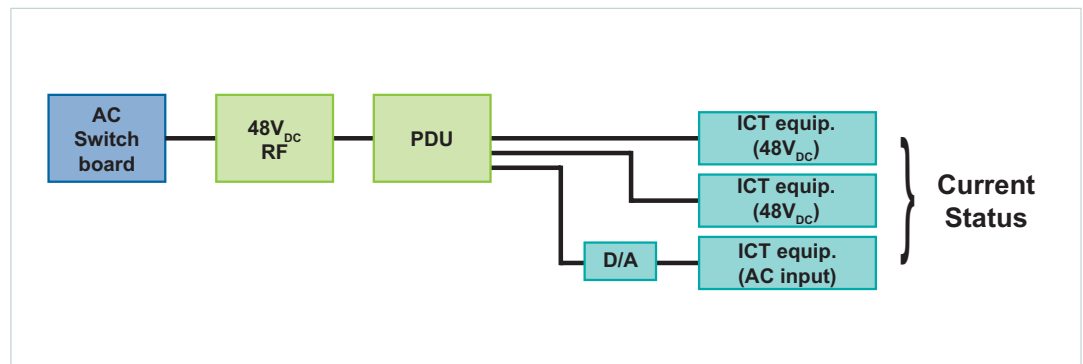
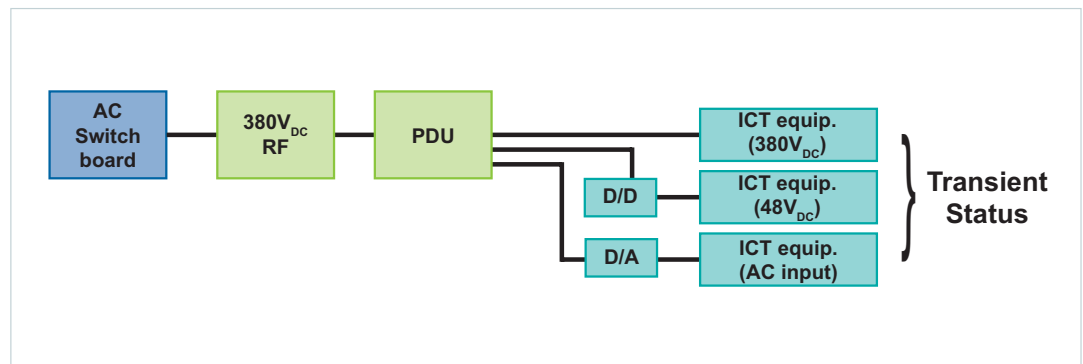

Figure 9
The transition phase uses a combination of rectifier, step-up and step-down stages



In this way, HV DC can be phased in without ripping "everything" out, which would be a costly and impractical requirement. After the transitional period, the intermediate voltage conversion after the PDU could be unnecessary: the 380V_{DC} would go directly to the loads to be converted down to the final needed voltages in a single step, Figure 10.

Figure 10

As the technology and approach becomes established and accepted, the 380V high-voltage DC would go directly to the loads and then converted to the lower-voltage rails in a single stage

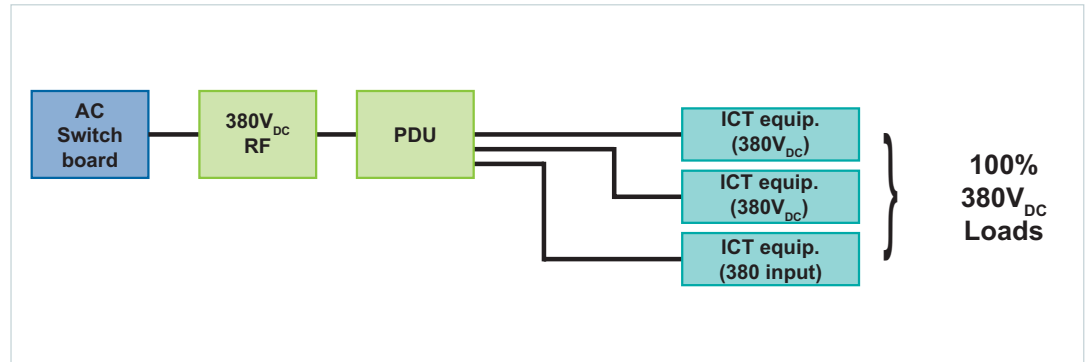

A tangible demonstration

Block diagrams and proposed architectures are good, but a working model is better, as shown by a complete 400V_{DC} system built using available, appropriate connectors, fuses and distribution, Figures 11 and 12. This collaboration between Emerson, Vicor, Anderson Electric and Fujitsu powered multiple loads including an Intel VR12 processor, a LAN switch, a 1U server, a PC and a monitor. As further testimony to the concept's validity, the 48V was directly down converted using a buck-boost plus bus-converter-like unit to 1V without additional intermediate steps for the processor, yielding about 5% greater efficiency than the traditional approach.

Figures 11 & 12

This working model shows a complete 400V_{DC} system built using commercially available connectors, fuses and distribution cabling

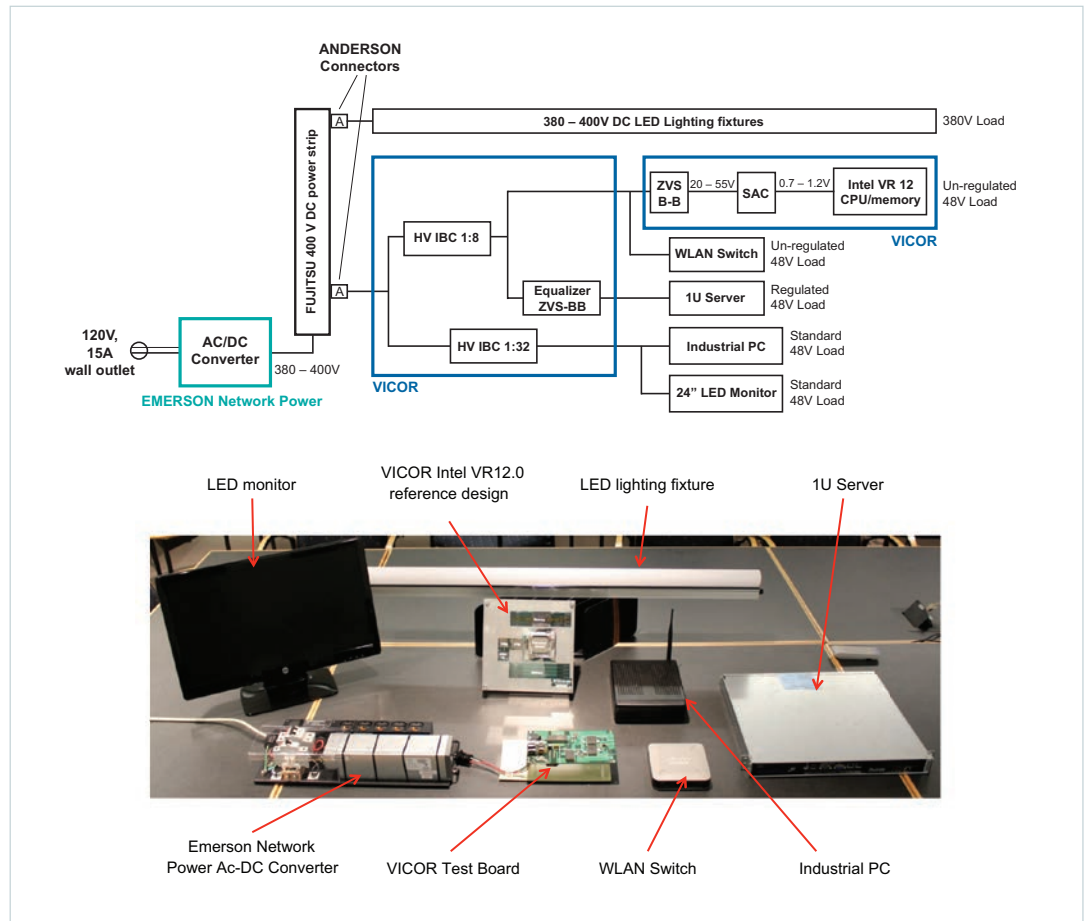

The challenges and opportunities ahead

A combination of factors is making high-voltage DC a very attractive solution to the energy consumption dilemma. The merging of voice-centric telecom with data-centric networking (voice, video, data) is driving increased power usage from information sources through end users. At the same time, we face climate-change issues, limits on fossil fuels and a need to integrate renewable sources. Initiatives such as the Kyoto Protocol (1997), the Copenhagen Accord (2009) and the European Council 20-20-20 Energy Strategy provide a regulatory framework and set of ambitious goals for reducing emissions of greenhouse gases, lowering energy consumption and increasing use of renewable sources.

The electronics industry will be a big part of responding to these initiatives and meeting these goals. It must be inventive, with radical, dramatic solutions rather than just incremental upgrades. It must be proactive, at the leading edge of the transition, while using proven, safe, demonstrable technologies which can shorten time to market. It must also collaborate on an industry-wide basis with alliances among various vendors and organizations to set comprehensive standards, define commonalities and minimize barriers to adoption.

At the same time, the plan, process and products must be commercially viable to encourage worldwide involvement and adoption. Yes, these big challenges require big thinking and transformations, but this industry has repeatedly shown it can act to meet and even lead them, as demonstrated by its many radical transitions in process, products and implementation over the years.

Contact Us: <http://www.vicorpower.com/contact-us>

Vicor Corporation

25 Frontage Road
Andover, MA, USA 01810
Tel: 800-735-6200
Fax: 978-475-6715
www.vicorpower.com

email

Customer Service: custserv@vicorpower.com
Technical Support: apps@vicorpower.com